

SIXTH FRAMEWORK PROGRAMME  
PRIORITY 8: Policy-Oriented Research



SPECIFIC TARGETED RESEARCH PROJECT n°SSPE-CT-2004-503604

Impact of Environmental Agreements on the CAP

Document number: MEACAP WP3 D7b  
Dissemination level: public

## **Bioenergy production and provision chains**

Authors: A. Weiske, G. Schröder, W. Bohnenschäfer, D. Falkenberg,  
N. Fröhlich, F. Müller-Langer, D. Thrän, A. Vogel

Author's Organisation(s): Institute for Energy and Environment (IE)

**Date: June 2005**

**TABLE OF CONTENTS**

Introduction .....	4
Rape cultivation (rape seed) .....	8
Olive tree cultivation .....	11
Soybean cultivation .....	13
Sunflower cultivation .....	15
Sugar beet cultivation .....	17
Winter wheat cultivation .....	20
Winter rye cultivation .....	22
Barley cultivation .....	24
Triticale cultivation .....	26
Maize cultivation .....	28
Potato cultivation .....	30
Sweet sorghum cultivation .....	32
Hemp cultivation .....	34
Miscanthus cultivation .....	36
Willow cultivation .....	38
Poplar cultivation .....	40
Grass cultivation (i.e. perennial ryegrass) .....	42
Straw from cereals cultivation (i.e. wheat) .....	44
Collecting of animal excrements .....	46
Collecting of vegetable residues from agriculture .....	48
Vegetable oil from rape seed .....	49
Vegetable oil from olives .....	52
Vegetable oil from soybeans .....	54
Vegetable oil from sunflower seeds .....	56
Methanol from woody biomass .....	58
Pyrolysis oil from biomass .....	60
Synfuel by therm. processing from biomass .....	62
Ethanol from sugar beet .....	64
Ethanol from maize .....	66
Ethanol from cereals .....	68
Ethanol from potatoes .....	70
Ethanol from wood or straw .....	72
Biogas from animal excr. or non-woody plants .....	74
Wood combustion for electricity/heat generation .....	76
Straw combustion for electricity/heat generation .....	77
Biogas combustion for electricity/heat generation .....	78
Hydrogen from electrolysis .....	79
Hydrogen from biomass by thermochem. conv. .....	80
Hydrogen from natural gas .....	82
Esterification of vegetable oils .....	83

Methyl ester from used vegetable oils.....	85
Biogas upgrading.....	86
Liquefaction of hydrogen .....	88
Compression of hydrogen .....	89
ETBE from ethanol .....	90

## Introduction

Since the European Community has ratified a range of international environmental agreements, certain obligations are bound to be fulfilled. Included are commitments under the Kyoto Protocol and the Convention on Biological Diversity (CBD). Agriculture could contribute in various ways to meet these objectives.

In order to achieve a positive and sustainable development in the European countries, analysis and evaluation of the possible adaptations and innovations in the agricultural sector are required. The most promising solutions concerning efficiency, environmental outcomes and economy are bound to be analysed more closely. Interactions between measures need to be studied alongside. This accounts for a wide range of conditions in Europe and the new Member States.

Adaptations and innovations in agriculture and forest management have to be supported by political measures and rural development policies that influence farm level and upwards. These measures are surrounded by EU legislation.

Before the set-up of specific objectives and practices in agriculture and forestry is described the background of policies and legislation, at an international level, is laid out briefly.

### European measures in energy policy

#### White paper for renewable sources of energy (1997)

The European Commission set an indicative target of 12 % for the contribution of renewable energy sources to the EU gross inland energy consumption by 2010. Furthermore, different shares of specific renewable energy sources were expressed. Biomass should contribute with approximately 5,740 PJ per year in 2010. Further distinctions about the biomass sources (solid, liquid or gaseous) have not been made.

These targets in the white paper are the basis for the measures and objectives that are described in the following. They resulted in specific objectives for each member country.

#### Directive on the promotion of electricity produced from renewable energy sources in the internal electricity market (2001), Directive 2001/77/EC

To support the aims of the white paper the directive on electricity from renewable energy sources (RES) came into force in 2001. The share of electricity from RES in the EU should rise from 14 % in 1997 to about 22 % in 2010. Indicative objectives for each member state have been determined. The environmental outcome of this directive should be the major share of all specific actions, taken from the EU.

#### Directive on the promotion of co-generation of heat and power based on a useful heat demand in the internal energy market (2004), Directive 2004/8/EC

In 2004, different methods of declaration and feed-in possibilities of electricity from co-generation have been harmonised by the Council. The originally formulated aim, the provision of 18 % of co-generation electricity, did not withstand. The directive points out that different circumstances in each member country have to be considered. Special aim and measures, to use biomass in co-generation plants were not defined. Therefore, no results in a European context are bound to be recognised.

#### Directive on promotion of the use of biofuels or other renewable fuels for transport (2003), Directive 2003/30/EC

The use of biofuels and other renewable sources of energy for transport was promoted by a directive in 2003. All member states should assure, that 2 % of the total fuel demand will be provided by RES in 2005. This share should increase to 5.75 % in 2010. Supporting measures

and the actual share are reported yearly to the Commission by each Member State. If targets were not reached, the Council might declare binding figures to the Member State.

Because of this mandatory influence, it is assumed that this directive will lead to an accelerated market-share of biofuels in Europe.

#### Directive on restructuring the Community framework for the taxation of energy products and electricity (2003), Directive 2003 /96/EC

The directive on the promotion of the use of biofuels (Directive 2003/30/EC) is accompanied by this directive. It allows Member States to reduce or delete the taxes on e.g. pure biofuels. The directive regulates the taxation of energy products and electricity. Products or energy from RES can be distributed tax-reduced or even tax-free.

#### Obligations voluntarily undertaken by automotive manufacturers concerning GHG emissions

Automotive manufacturers in Europe, Japan and Korea have obliged themselves to reduce the average GHG emission from cars by 25 % per km in 2009 compared to 1999. Only an increasing use of gasoline cars, since 1999 had major influence on the emission. It is estimated, that the obligation will not be met, since the reduction rate per year is too small so far.

#### Directive establishing a scheme for greenhouse gas emission allowance trading within the Community and amending Council Directive 96/61/EC, Directive 2003/87/EC

Aim of this directive is to set up a system of emission trading in Europe. In 2005, allowances were declared and distributed by the members of the Community. After the year 2008 trading will take place and new declaration in five-yearly intervals are declared and distributed. Progress in building up trading systems can be recognised in different member states. After 2010 relevant effects are assumed to be recognisable in the Community.

#### Campaign for take-off

In 1999, a campaign for take-off (lasting 4 years) had been launched to promote the aims of the white paper. Background information and market presence of RES were major topics. In the sector of biomass following targets (not obligatory) have been pronounced:

- additional 10,000 MW<sub>th</sub> heat from biomass co-generation plants
- one additional million of houses, heated with biomass
- additional 1,000 MW fermentation systems to produce biogas
- production of 5 Mio. Mg biofuels

The indicative figures have not been specified in accordance to the different member states.

The campaign for take-off is followed by a campaign for sustainable energy that is set up at presence.

### **European status quo in the energy sector**

The directives and other instruments led to different measures, being realised in the Member States of the Community (see D7c). Tax releases, subsidies or feed-in tariffs were implemented. Quotas on RES or NFFO (non-fossil fuel obligations) are other instruments to be mentioned. All instruments help to increase the portion of renewable energies contributing to the market. Many instruments are electricity related. Heat related instruments have not been established in equivalent numbers so far. In face of these instruments the obligations, as laid out in the white paper, will not be met, if the actual trends are subscribed until 2010. Only a few Member States can meet their obligations. Reasons might lie in the transportation sector, where the trend to increasing emissions could not be changed or within the domestic sector, where far more buildings in total result in more emissions. To solve these problems and speed up the development a coordinated action plan concerning biomass will be released in 2005.

## Structure and methodology

After the politically and legislative background of renewable energies - and especially biomass - has been briefed, the method and structure of biomass production and provision chains are described.

Providing energy from biomass has a wide range of varieties. Possible are, on the one hand, very short and "ordinary" provision chains like e.g. "collecting wood" and "burning it" in a combustion system to produce heat. On the other hand exist very long and complex bioenergy production and provision chains with many transformation steps, like e.g. the production of ethanol from wheat to be used as a fuel in transportation.

To get a better structured view on the wide range of energy sources and technologies the description of the production and provision chains was established in a modular manner. The modules are divided into two different groups.

- The first group includes module sheets for primary energy sources (comprises production of energy plants (P) and organic residues (R)).
- The second group includes module sheets describing different kinds of conversion technologies (comprises processing of oil plants (O), thermochemical conversion (T), fermentation (F), electricity from biomass (E), production of hydrogen (H) and secondary processing (S)).

Each module sheet includes a general description of the state of art of the issue in Europe. Some quantitative figures concerning relevant parameters of the process are recorded. Finally, regional aspects are considered and the possible development of the state of the art in the near future is mentioned. The module sheets are modified for each group concerning the specific distinctions of the issues.

The figure on the next page provides an overview of all modules as arranged in the two major groups of bioenergy production and provision chains.

## Module sheets for primary energy sources

Cultivation of Energy Plants (P)			
Oil Plants			
<b>P1</b>	Rape seed	<b>P2</b>	Olive tree
<b>P3</b>	Soy bean	<b>P4</b>	Sunflower
Other Plants			
<b>P5</b>	Sugar beet	<b>P6</b>	Wheat
<b>P7</b>	Rye	<b>P8</b>	Barley
<b>P9</b>	Triticale	<b>P10</b>	Maize
<b>P11</b>	Potato	<b>P12</b>	Sweet Sorghum
<b>P13</b>	Hemp	<b>P14</b>	Miscanthus
<b>P15</b>	Willow	<b>P16</b>	Poplar
<b>P17</b>	Grass		

Collection of Organic Residues (R)			
Straw and Similar Residues			
<b>R1</b>	Straw from cereals cultivation		
Collection of Organic Waste			
<b>R2</b>	Animal excrements	<b>R3</b>	Vegetable residues from agriculture

## Module sheets for transformation technologies

Pressing of oil Plants (O)			
<b>O1</b>	Rape seed oil	<b>O2</b>	Olive oil
<b>O3</b>	Soy bean oil	<b>O4</b>	Sunflower oil

Thermochemical Conversion (T)			
<b>T1</b>	Methanol from woody biomass	<b>T2</b>	Pyrolysis oil from biomass
<b>T3</b>	Synfuel by therm. processing from biomass		

Fermentation (F) (Ethanol/Gas)			
<b>F1</b>	Ethanol from sugar beet	<b>F2</b>	Ethanol from maize
<b>F3</b>	Ethanol from cereals	<b>F4</b>	Ethanol from potatoes
<b>F5</b>	Ethanol from Wood or straw	<b>F6</b>	Biogas from animal excrements or non-woody plants

Electricity from Biomass (E)			
<b>E1</b>	Wood combustion for electricity generation	<b>E2</b>	Straw combustion for electricity generation
<b>E3</b>	Biogas combustion for electr. generation		

Production of Hydrogen (H)			
<b>H1</b>	from electrolysis	<b>H2</b>	from biomass by thermochemical conversion
<b>H3</b>	from natural gas		

Secondary Processing (S)			
<b>S1</b>	Esterification of Vegetable Oils	<b>S2</b>	Methyl ester from used vegetable oil
<b>S3</b>	Biogas Upgrading	<b>S4</b>	Liquefaction of Hydrogen
<b>S5</b>	Compression of Hydrogen	<b>S6</b>	ETBE from Ethanol



Module	P1	Rape cultivation (rape seed)
<b>General description of the process, regional aspects, outlook</b>		

Rape is an annual C3 plant which originated from the Mediterranean region. It is a member of the *Cruciferae* family, and has both winter and spring forms. The plant germinates quickly, forming a deep growing tap root and a rosette of blue-green leaves from which emerge 7-10 lateral shoots. On the ends of the branched stems grow the gold-yellow flowered racemes. Each plant has approx. 120 long slender seed pods, each plant produces 2,000-3,000 seeds. The winter rape vegetation period is about 330 days (August-July), spring rape vegetation period is about 180 days (April-September).

Rape seed has many uses e.g. hydraulic oil, chain saw oils, fuel.

### **Agronomic requirements**

Rape is an ecologically demanding plant. A deep sandy loam rich in humus and nutrients and with an optimal lime content is the most appropriate soil for rape cultivation, followed by humic loam, loam and clay loam in decreasing order of suitability. Humic and loamy soils can be appropriate when a sufficient water supply is guaranteed in April, though in general the success of the crop is greatly influenced by a sufficient water supply during the vegetation period. Because of spring rape's weaker root development it is more sensitive to water deficit than winter rape. After sowing winter rape, the plant should have about 100 days with temperatures over 2 °C to reach the 8-10 leaf stage and develop the tap roots necessary for wintering. The winter can be moderately cold with a light snow cover. There should be very little spring frost, and the spring should be moderately warm. In late winter/early spring when the temperature remains constantly above 5 °C the plant will begin leaf growth.

### **Crop management**

Winter rape is sown in the middle of August to the beginning of September. The desired crop density is between 60-80 plants m<sup>-2</sup> which is achieved by using 3-4 kg of seed per hectare. The seed should be planted at a depth of 1-2 cm. Spring rape is sown from the end of March to the beginning of May. The double amount of seed (compared with winter rape) may be necessary to obtain the same desired crop density. Problem weeds are: chickweed, field foxtail grass, couch grass, camomile, blind nettle, pansy, annual wild oats and reappearing wheat, among others. Therefore, herbicides and fungicides may be used according to actual demand. Insecticides can be used to combat the variety of pests which infest rape crops. These pests include fleas, lice, snails, pollen beetles and weevils. Organic fertilisation using liquid manure is possible and recommended. Fertiliser levels as recommended in Germany are  
 for winter rape: nitrogen 0-50 kg ha<sup>-1</sup> (in autumn), nitrogen up to 100 kg ha<sup>-1</sup> (vegetation start), nitrogen 80-100 kg ha<sup>-1</sup> (4 weeks later), phosphorus 100 kg ha<sup>-1</sup>, potassium 220 kg ha<sup>-1</sup>, magnesium 25-30 kg ha<sup>-1</sup>

for spring rape: nitrogen 80-100 kg ha<sup>-1</sup> (with sowing), nitrogen 60-80 kg ha<sup>-1</sup> (at 6-8 leaf stage), phosphorus 80 kg ha<sup>-1</sup>, potassium 120 kg ha<sup>-1</sup>, magnesium 40 kg ha<sup>-1</sup>.

Winter rape has a yearly average seed yield of about 3 t ha<sup>-1</sup> and a dry matter straw yield of 10-12 t ha<sup>-1</sup>.



### **Crop rotation**

Crops coming before rape should be early harvested crops such as winter barley or peas. Because of the danger of nematodes infesting the crop, rape should be combined with e.g. sugar beets in its crop rotation. A break in rape cultivation of 4-5 years should be adhered to. The lowest yields were obtained when rape was grown in monoculture. It was found that in general the yields of oilseed rape increased with the length of the rotation and the length of the break between two rape crops.

### **Regional aspects**

Spring rape is planted, usually in northern latitudes, where the winters are too severe for winter rape to survive the hibernation period.

### **Outlook**

It is assumed that the development of agriculture will not lead to an increase in yields in the EU 15 countries and but will lead to yields in the new member states (NMS) to reach those in the EU 15.

<h3><b>Provision chains</b></h3>
----------------------------------

The aim of different extraction processes (downstream) is to separate the oil phase from the seed most efficiently. Parts of the seed are not wanted in the oil and have to be separated. Treatment like drying and cleaning, transport and storage already have great influence on the quality of the oil before the literal process of oil extraction.

### **Treatment**

At the time of harvest the moisture content of the rape seed has sunk to under 20 %. Drying may be necessary to achieve the desired 9 % moisture content which makes the seed storable and ready for further processing. Usually, drying is the first step of treatment since moist seeds and impurities tend to block screens or filters. The second step is cleaning the seed to remove impurities like dust, sand, wood, plant rests (pieces of stems and leaves), metal pieces and extrinsic seeds. A high percentage of impurities leads to less quality oils and increases abrasion in the oil mill.

The straw can be immediately chopped up to be used for fodder, or dried for storage or further processing.

### **Transportation**

Transportation has to ensure the good condition of seed (concerning moisture and purity). Depending on the size and location of the oil mill either ships, trains or trucks are used for transportation.

### **Storage**

After the different steps of treatment the seeds can be stored with a minimum loss on dry matter per year (at a moisture content of 9 % about 0.4 % of dry matter per year is lost, respectively 0.1-0.2 % is lost at 7-8 % moisture content). The storage has to ensure good condition of the seed (concerning moisture and purity). Furthermore, low temperatures, ventilation and shifting of storage improve conditions.

## Sources

- (1) [www.fao.org/regional/europe/escorena/b46/cover.pdf](http://www.fao.org/regional/europe/escorena/b46/cover.pdf) "RENEWABLE ENERGY- Potential energy crops for Europe and the Mediterranean region" Regional Office For Europe (REU).
- (2) Federal Agricultural Research Centre (FAL) Braunschweig, Germany.
- (3) Reinhardt, G., Zemanek, G. (2000): Ökobilanz Bioenergieträger, Erich Schmidt Verlag, Berlin, 2000.
- (4) Statistisches Jahrbuch über Ernährung, Landwirtschaft und Forsten 2001, Münster, 2001.
- (5) Kaltschmitt, M., Hartmann, H. (2001): Energie aus Biomasse, Springer Verlag, Berlin, 2001.
- (6) Reinhardt, G., Kaltschmitt, M. (1997): Nachwachsende Energieträger, Vieweg Verlag, Braunschweig / Wiesbaden, 1997.
- (7) [www.eu-datashop.de/download/DE/sta\\_kurz/thema5/nn\\_02\\_06.pdf](http://www.eu-datashop.de/download/DE/sta_kurz/thema5/nn_02_06.pdf).



<b>Module</b>	<b>P2</b>	<b>Olive tree cultivation</b>
<b>General description of the process, regional aspects, outlook</b>		

The olive tree is a member of the *Oleaceae* family. It is an evergreen that can take on different shapes and sizes. Its lanceolate leaves are on average 5-8 cm long; they are green on the upper side and silver-grey on the lower, and last about 3 years. The trunk is grey-green and smooth until about the tenth year, then it becomes knotty, twisted, rough with deep furrows, and it takes on a dark colour, almost black. At the bottom a wide stump can grow sprouts even after the trunk has been cut, thus assuring survival of the tree. The roots form clusters and many surface ramifications which absorb most of the nourishment. They spread horizontally up to 2-3 times the height of the tree, and in the most fertile soils they run up to 1.5-2 meters deep.

The final manufactured products from olive trees are fruits and olive oil. Olive oil is extracted from the fruit. It is used in cooking, cosmetics and soaps. It can be used as a fuel like rape oil. The fruits are used as food.

### **Agronomic requirements**

The olive tree is very robust: in winter it can endure temperatures below  $-6^{\circ}\text{C}$ , and in summer long periods of drought. It is cultivated in areas with an average rainfall of 350-400 mm per year, and summer temperatures of  $40^{\circ}\text{C}$ . The cultivation area of the olive tree is between the  $30^{\circ}$  and  $45^{\circ}$  latitude. In order to obtain a good yield it is necessary to carry out a cultivation programme.

### **Crop management**

The olive tree life cycle is as follows. From 0-7 years of age the tree is unproductive. From 7-30 years of age the tree grows with a constant increase in productivity. From 35-150 years the tree reaches maturity and full production. At 150 years the olive tree starts aging with a remarkable productivity for centuries and sometimes for thousands of years. The olive trees production is cyclical with more production in one year and significantly less in the following year. This cycle is repeated throughout the life of the tree. In spring the soil around the tree must be fertilised and tilled for improved storage of water near the roots. The trees must also be pruned at this time. The spring fertilisation provides mineral and other necessary substances for blossoming, adjusts the ratio of those contained in the soil, or supplements them if they are scarce. It has been estimated that 100 kg of olives remove from the soil an average of 818 g of nitrogen, 182 g of phosphoric dioxide and 90 g of potassium. Organic fertilisers are often used. Trees are watered every 2-3 weeks during the summer months when the fruit is in its early stages of growth. In the summer period olives can be damaged due to exposure to harsh weather, disease and parasites. Olive fly is the most feared enemy. In certain years this insect can destroy the entire crop. The larvae cause premature fruit drop and yield reduction. Combating olive fly is done through the use of antiparasitics, poisoned bait and certain parasites that attack its larvae during the summer. During autumn the olives grow ripe and they lose their green colour due to the increase in oil content and the decrease in water content. In this period the olive tree requires a constant supply of minerals and other substances otherwise the tree's productivity can decrease in the following year. The soil surrounding the plant is treated at the maximum depth of 20 cm in order to avoid damaging surface root. This treatment allows the mixing of fertiliser with the soil and prepares the soil

to receive rain water and to maintain humidity as long as possible. During winter the olives must be harvested when they are  $\frac{3}{4}$  violet and before they become fully ripe, accumulated oil in the fruit then starts to decrease.

Olive trees have an average yield of about  $2.4 \text{ t ha}^{-1}$ . The oil content ranges from 5-30 %, regarding the volume.

### **Crop rotation**

Because olive tree is a perennial crop, a crop rotation may not be necessary for more than 150 years.

### **Regional aspects**

Olive trees do best in Mediterranean climate (Spain, Italy, Greece, South France) with hot, dry summer and a cool, wet winter.

### **Outlook**

Implementation outside the Mediterranean area can not be seriously considered. If cultivation areas have to be enlarged, the growing period of 30 years has to be taken into account. The availability of more olives can not be increased in a short- or middle-term period for this reason.

### **Provision chains**

Since most of the olive oil is used in the nourishment industry almost no industrial sized oil production has been established so far. Olive oil mills are located in the region of harvest to reduce transport distances. Olives are not stored over a longer period of time. Aim of the extraction process (downstream) is to separate the oil phase from the fruit most efficiently. To improve oil quality, treatment like cleaning and washing of the olives with water may be utilised.

### **Sources**

- (1) [http://www.superquinn.ie/nutrition/food\\_facts\\_olives.html](http://www.superquinn.ie/nutrition/food_facts_olives.html).
- (2) [www.rezepte-cocktails.de/ernaehrung\\_olivenoel.htm](http://www.rezepte-cocktails.de/ernaehrung_olivenoel.htm).
- (3) Reinhardt, G., Zemanek, G. (2000): Ökobilanz Bioenergieträger, Erich Schmidt Verlag, Berlin, 2000.
- (4) <http://www.elikioliveoil.com>.
- (5) Statistisches Jahrbuch über Ernährung, Landwirtschaft und Forsten 2001, Münster, 2001.
- (6) Kaltschmitt, M., Hartmann, H. (2001): Energie aus Biomasse, Springer Verlag, Berlin,..., 2001.



Module	P3	Soybean cultivation
<b>General description of the process, regional aspects, outlook</b>		

Soybean is an annual bush-like C3 plant originating from China. It grows to a height of up to 80 cm with all plant-parts being hairy. The plant produces a main root with smaller roots branching from it. The smaller roots possess numerous nodules inside of which develop the bacteria *Bradyrhizobium japonicum*. The bacteria are responsible for free nitrogen fixation. Above the cotyledonary nodes develop two single leaflets opposite each other. The plant's other leaves consist usually of three leaflets. Soybean is mostly self-fertilising. Numerous very small purple or white flowers are found in compact racemes in the leaf axils. These racemose inflorescences growing from the leaf axils are responsible for the production of the plant's fruit which develops in the form of pods. Although 1-5 seeds per pod can be found, the usual number is 2 or 3. The seeds are round to oval with a whitish-yellow to brown/black-brown colour. Their composition ranges from approximately 38-43 % protein, 18-25 % oil and 24 % carbohydrates. The crop has about a 4-5 months growing period.

Soybeans currently have a very wide range of food and non-food uses, e.g. soy milk, soy meal, emulsifier for pharmaceuticals and pesticides. The oil extracted from the seeds can be used as a fuel.

### **Agronomic requirements**

Soybean plants are adaptable to a wide range of environments. This adaptability is possible because of the many different cultivars, each having its own characteristics and preferred conditions. Soybean has similar ecological requirements to maize. The plant desires high temperatures in the summer and autumn to facilitate ripening. Loamy soil or loess and black soil with a good ability to hold water are recommended. When enough water is present a light sandy soil can also be used. A constantly humid subtropic climate is most favourable for soybean crops. Although the temperatures 24-25 °C are preferred for optimal growth, the range of 20-25 °C is still excellent for all stages of plant growth. Frost tolerance is better than that of maize. The rainfall required for a good yield in warmer areas is 500-750 mm though less precipitation during ripening is preferred. The pH-range of 6-6.5 has been shown to be the most desirable for soybean crops, with instances of certain cultivars performing better at slightly more acidic or basic levels. Rhizobium symbiosis is an important factor when it comes to crop growth and yield.

### **Crop management**

Sowing should take place in the middle of April / beginning of May. The ground temperature at a depth of 5 cm should be at least 10 °C. A sowing depth of 3-4 cm and a distance between rows of 25-30 cm is recommended. The desired crop density is 40-60 plants m<sup>-2</sup>. This corresponds to a seed sowing amount of about 70-90 kg ha<sup>-1</sup>. Since high soil temperatures negatively affect the N<sub>2</sub> binding potential of soybean's nodules, regions in southern Europe and the Mediterranean should use denser crop spacings, thus shielding the soil in hotter climates. Because of the nitrogen-fixing bacteria most soils do not need supplementary nitrogen fertilisation, especially in the case of the previous crop having been abundantly fertilised. During the first few weeks after sowing weed control is essential. Drought or excessive dryness strongly affects crop yield in a negative fashion especially before flower

formation and during granulation. Disease damage to soybean crops can be greatly reduced by proper cultivar and seed selection, maintaining sanitary practices and appropriate crop rotation. The most destructive diseases affecting soybean crops are, among others, frogeye leaf spot, stem canker and soybean mosaic virus. Some of the more damaging pests are the soybean moth, the Japanese beetle and the soybean cyst nematode. If these pests are present, insecticides may be necessary. 15 kg phosphorus and 50 kg potassium are used from the soil for every ton of seeds produced.

Soybeans have an average yield of about 3 t ha<sup>-1</sup> and an oil content of 20 %.

### **Crop rotation**

Soybean can be used with a large variety of crop rotation plans. Usually soybean comes between two grain or cereal crops. Possible rotation combinations are: maize-soybean-wheat, soybean-wheat-sorghum, millet-winter wheat-soybean, or maize-soybean-cotton.

### **Regional aspects**

Because high soil temperatures negatively affect the N<sub>2</sub> binding potential of soybean's nodules, regions in southern Europe and the Mediterranean should reduce crop spacings, thus shielding the soil in hotter climates.

### **Outlook**

It is assumed that the development of agriculture will not lead to higher yields in the EU 15 and new EU countries.

### **Provision chains**

A combine harvester can be used for harvesting soybean crops. The plants are harvested when the leaves turn yellow and the plant dies. At this time the seeds are fully ripe, but the pods have not yet ruptured. The water content of the seeds should be under 20 % at the time of harvest. The harvested beans are prepared for storage by being cleaned and dried to a moisture content of 12-14 %. After this treatment the beans can be stored in elevators or silos and can be transported in appropriate vehicles. This provides a continuous, year-round supply of beans for further processing

### **Sources**

- (1) [www.fao.org/regional/europe/escorena/b46/cover.pdf](http://www.fao.org/regional/europe/escorena/b46/cover.pdf), "RENEWABLE ENERGY-Potential energy crops for Europe and the Mediterranean region" Regional Office For Europe (REU).
- (2) Federal Agricultural Research Centre (FAL) Braunschweig, Germany.
- (3) Reinhardt, G., Zemanek, G. (2000): Ökobilanz Bioenergieträger, Erich Schmidt Verlag, Berlin, 2000.
- (4) Statistisches Jahrbuch über Ernährung, Landwirtschaft und Forsten 2001, Münster 2001.
- (5) Kaltschmitt, M., Hartmann, H. (2001): Energie aus Biomasse, Springer Verlag, Berlin, ..., 2001.
- (6) Reinhardt, G., Kaltschmitt, M. (1997): Nachwachsende Energieträger, Vieweg Verlag, Braunschweig / Wiesbaden, 1997.
- (7) [www.eu-datashop.de/download/DE/sta\\_kurz/thema5/nn\\_02\\_06.pdf](http://www.eu-datashop.de/download/DE/sta_kurz/thema5/nn_02_06.pdf).



<b>Module</b>	<b>P3</b>	<b>Sunflower cultivation</b>
<b>General description of the process, regional aspects, outlook</b>		

Sunflower is an annual C3 plant which originated from America. Sunflower belongs to the genus *Helianthus* of the *Compositae* family. The inflorescence of the plants of this family are heads in which the fertile flowers are aggregated and bordered by rays, the corollas of sterile flowers. The genus *Helianthus* includes 67 annual and perennial species. The cultivated sunflower is an annual plant with the scientific name of *Helianthus annuus*. It is an erect, unbranched, coarse annual, with a distinctive large, golden head, the seeds are often used for the production of sunflower oil. The plant having a well developed root system is considered as one of the most drought resistant crops suitable for the southern semi-arid countries. The vegetation period is about 150 days (April-August).

Sunflower seed is used as nourishment and for oil production. The oil extracted from the seed can also be used as a fuel.

#### **Agronomic requirements**

Sunflower is a well-adapted crop under various climatic and soil conditions. Under moisture stress conditions the number and the size of the leaves are reduced. A satisfactory crop can be produced, without irrigation, even in winter rainfall regions of approximately 300 mm. Growth is satisfactory when temperatures do not fall below 10 °C, but it can resist far lower temperatures. The young plants can withstand considerable freezing until they reach the 4-6 leaf stage, and the ripening seeds suffer little damage from slight frost. It requires ample sunlight and needs an average temperature of 14 °C during the vegetation period. The sunflower grows on a variety of soils ranging from sand to clay. In low fertility soils its performance is better in comparison with other crops such as maize, potato and wheat. The best pH range is between 6.5-8. It is considered slightly susceptible to salts.

#### **Crop management**

The seed should be placed in moist soil and rapid drying out of the seedbed should be avoided. Sunflower seeds are capable of germinating even at 5 °C, but in practice more than 10 °C are required for satisfactory germination and even higher for satisfactory emergence. Generally, it is possible to sow sunflower fairly early in spring. The desired crop density is between 35-60 plants per m<sup>2</sup> which is achieved by using 5-15 kg seeds per hectare. Usually, early plantings lead to higher seed yields and higher oil content of seeds. Distances of 75 cm between rows are very common. In the early growth stages sunflower is sensitive to weed competition. A pre-emergence harrowing or pre-emergence herbicides are used for the control of the weeds. One of the most common fungal diseases of sunflower is rust, caused by *Puccinia helianthi*. Several other fungal diseases, of minor importance, attack sunflower. Among them are charcoal rot, downy mildew, powdery mildew and leaf spot wilt. Several insects attack sunflower, sunflower beetle, aphid grasshoppers. In non-irrigated fields sunflower response to fertilisers is very limited, as is the case with many other non-irrigated spring grown crops. In irrigated fields of low fertility nitrogen fertilisation response is positive. Nitrogen fertilisation rates from 50-80 kg ha<sup>-1</sup> are recommended. Nitrogen application must be related to the availability of phosphate and potash. If these are deficient, nitrogen usually depresses yield and seed-oil content.

Sunflowers have an average yield of about 1.7 t ha<sup>-1</sup>. In oil producing varieties the seeds contain up to 40-50 % of oil.

### Crop rotation

Sunflowers can add diversity to a rotation and can be successfully used in annual cropping systems that utilise no-till. Crop rotation is important for preventing diseases such as white mould, Verticillium wilt, Phoma and premature ripening.

### Regional aspects

Sunflower cultivation is limited to southern and central Europe. Yields are different in each country and range between 0.5-2.7 t ha<sup>-1</sup>.

### Outlook

It is assumed that the development of agriculture will not lead to other yields than today in the EU 15 and new EU countries.

### Provision chains

Sunflower heads should be fully mature before **harvesting**. It is estimated that during the last fourteen days of maturation the dry matter of the seeds may increase by 50-100 %. However, seed maturation in a head is not uniform. Delaying harvesting until all the seeds are fully mature may cause significant losses due to shattering and losses from birds that eat the seeds. However, even at this stage a fair proportion of seeds contain up to 50 % moisture. This should be taken into account for a safe **storage** since the maximum moisture content at storage should not exceed 9 %.

For dwarf varieties harvesting is done with a **cereal combine machine**, equipped with a special attachment on the header. In oil producing varieties the pericarp ranges from 22-28 % and the kernel from 72-78 %. The kernels are rich in oil. The average oil composition of such achenes ranges from 40-50 %, the protein content from 15-20 % and the fibre content from 10-15 %.

### Sources

- (1) [www.fao.org/regional/europe/escorena/b46/cover.pdf](http://www.fao.org/regional/europe/escorena/b46/cover.pdf) "RENEWABLE ENERGY- Potential energy crops for Europe and the Mediterranean region" Regional Office For Europe (REU).
- (2) Federal Agricultural Research Centre (FAL) Braunschweig, Germany.
- (3) Reinhardt, G., Zemanek, G. (2000): Ökobilanz Bioenergieträger, Erich Schmidt Verlag, Berlin, 2000.
- (4) Statistisches Jahrbuch über Ernährung, Landwirtschaft und Forsten 2001, Münster 2001.
- (5) Kaltschmitt, M., Hartmann, H. (2001): Energie aus Biomasse, Springer Verlag, Berlin,..., 2001.
- (6) Reinhardt, G., Kaltschmitt, M. (1997): Nachwachsende Energieträger, Vieweg Verlag, Braunschweig / Wiesbaden, 1997.
- (7) [www.eu-datashop.de/download/DE/sta\\_kurz/thema5/nn\\_02\\_06.pdf](http://www.eu-datashop.de/download/DE/sta_kurz/thema5/nn_02_06.pdf).
- (8) [http://www.farmsource.com/ConTill/contill\\_pl\\_summer.asp](http://www.farmsource.com/ConTill/contill_pl_summer.asp).





Module	P5	Sugar beet cultivation
<b>General description of the process, regional aspects, outlook</b>		

Sugar beet is a biannual C3 plant and a member of the *Chenopodiaceae* family. In the sowing year it forms a rosette from upward-arranged, large, fleshy leaves as well as a wedge-shaped root. The yield organ consists of the thickened primary root as well as a part of the leafy top. It grows only little from the soil. The sugar beet vegetation period is about 210 days (March-September).

The main application of the sugar beet is the production of sugar. Sugar can be used to produce ethanol in a fermentation process. Ethanol may be used as a fuel substitute.

### **Agronomic requirements**

Sugar beet ranks among the products with the highest requirements for soil quality. The ideal climate for sugar beet production is uninterrupted summer sunshine, temperatures between 22-28 °C, and adequate reserves of available moisture. The presence of compacted layers in the soil profile creates conditions for poor rooting and inadequate plant growth. Compaction makes it difficult for plants to obtain sufficient water and nutrients, especially during dry periods. Sugar beet will grow under alkaline conditions, but prefers a neutral soil, taking up other crop nutrients most efficiently from most soils with a pH range of 6.5-7.0.

### **Crop management**

The sugar beet crop requires a fine, moist tilth at drill depth, permitting good seed to soil contact. The soil should be free of compaction to encourage deep rooting and maximum moisture extraction, as well as allowing free drainage. A progressive approach to soil preparation should lead by sowing time to a level surface for efficient drilling operations, a compaction free moisture retentive seedbed to aid germination and crop establishment, with good seed to soil contact. The soil should be uncompacted to full rooting depth, to allow deep rooting and free drainage. Beet seedlings (about 4 kg ha<sup>-1</sup>) are slow to emerge and establish in cold or dry soil conditions. Slow emerging seedlings are most at risk from pest and disease attack. The aim should always be to encourage rapid and uniform emergence and is best achieved when soil temperatures are moving upward from a base of 5 °C, with adequate seedbed moisture. The creation of a level, moist tilth without compaction can be achieved by just cultivating the friable surface soil - the friable surface being created by the repeated wetting and drying, freezing and thawing of the soil surface. The treatment of seed with a fungicide and insecticide is essential, particularly when crops are drilled to a stand. European pelleted seeds usually incorporate a fungicide (thiram or hymexacol), plus an insecticide such as imidacloprid (Gaucho). Pelleting allows fungicides and insecticides to surround the seed in a more measured dose, offering much more effective control. The most destructive diseases affecting sugar beet crops are, among others, black leg, downy mildew and rhizomania. Some of the more damaging pests are seedling pest and wireworm. If these pests are present, insecticides may be necessary.

For high yields the use of fertilisers is recommended:

nitrogen 120-160 kg ha<sup>-1</sup> (130), phosphorus 35-70 kg ha<sup>-1</sup> (50), potassium 170 kg ha<sup>-1</sup>, magnesium 35-50 kg ha<sup>-1</sup> (40).

Sugar beet has an average yield of about 54 t ha<sup>-1</sup> (fresh matter). It has a sugar content of 15-20 % by weight (relating to dry matter).

### **Crop rotation**

The rotation is the basis of effective beet crop production. Pest, disease and weed control are all influenced by the rotation. To avoid the build-up of beet cyst nematodes cruciferous host crops, i.e. oil seed rape, cabbage, turnips etc. should also be avoided in the rotation, or have at least a three year break between these crops and beet. On no account should sugar beet be grown closer than every third year (2 year break).

### **Regional aspects**

Sugar beet is not very frost resistant, so growth in countries with long winters is problematic.

### **Outlook**

It is assumed that the development of agriculture will not lead to increased yields in the EU 15 and new EU countries.

<b>Provision chains</b>
-------------------------

### **Treatment**

Harvesting is entirely mechanical. The sugar beet harvester chops the leaf and crown (which is high in non-sugar impurities and is left in the field) from the root, lifts the root, and removes excess soil from the root in a single pass over the field. A modern harvester is typically able to cover 6 rows at the same time. The beet is left in piles at the side of the field and then conveyed into a trailer for delivery to the factory. The conveyor removes more soil. In the fall harvest begins with the first hard frost, which stops photosynthesis and further growth of the root. Depending on the local climate, it may be carried out in few weeks or be prolonged throughout the winter months. The harvest and processing of the beet is referred to as "the campaign" reflecting the organisation required to deliver crop at a steady rate to processing factories that run 24 hours a day for the duration of the harvest and processing.

### **Storage**

If the beet is to be left for later delivery, it is formed into "clamps". Straw bales are used to shield the beet from the weather. In well-built clamps, with the right amount of ventilation, the beet does not significantly deteriorate. Beets that are frozen and then defrost produce complex carbohydrates that cause severe production problems in the factory. Loads may be hand examined at the factory gate.

### **Transportation**

After harvesting the beet are hauled to the factory. Delivery is by truck or, for local farmers, by tractor and trailer. Railways or boats are not used any longer.

<b>Sources</b>
----------------

- (1) [www.tacisinfo.ru/brochure/sugar\\_e/index\\_m.html](http://www.tacisinfo.ru/brochure/sugar_e/index_m.html).
- (2) <http://www.stichnoth.net/rapool/rapool.cfm?aktland=5>.
- (3) Reinhardt, G., Zemanek, G. (2000): Ökobilanz Bioenergieträger, Erich Schmidt Verlag, Berlin, 2000.
- (4) Statistisches Jahrbuch über Ernährung, Landwirtschaft und Forsten 2001, Münster 2001.

- (5) Kaltschmitt, M., Hartmann, H. (2001): Energie aus Biomasse, Springer Verlag, Berlin,..., 2001.
- (6) Reinhardt, G., Kaltschmitt, M. (1997): Nachwachsende Energieträger, Vieweg Verlag, Braunschweig / Wiesbaden, 1997.



Module	P6	Winter wheat cultivation
<b>General description of the process, regional aspects, outlook</b>		

Winter wheat is a member of the *Gramineae* family. It has a prostrate, semierect, or erect physical stature and possesses a fibrous root system. It is an environmentally demanding plant. Usually 5 sprouts are generated from the main sprout. On the ends of the branched sprouts grow the spikes. The vegetation period is about 330 days (October-August).

The grains are a basic input for the food industry; also there is the possibility to regenerate fuel from the grains. The whole crop can be used in combustion systems or as a co-substrate to produce biogas in biogas plants.

### **Agronomic requirements**

Winter wheat is the most ecologically demanding plant of cereals. It prefers deep, nutrient rich, soils, with a good water supply. Winter wheat can survive temperatures of about -20 °C. In the 3-5 leaf stage the winter wheat is very frost sensitive.

### **Crop management**

Winter wheat is normally sown in September-November and grows just a little before going dormant in winter. The seed should be planted at a depth 2.5-3.5 cm, the distance between the rows should be 12-20 cm. The desired crop density is between 350-420 plants m<sup>-2</sup>. Therefore, about 180-200 kg ha<sup>-1</sup> seeds are needed. After the floral initiation in January, the plants develop a number of tillers and are finally harvested in August. Mechanical or chemical weed combat is possible. Several diseases and pests have been known, e.g. fusarium, mildew, fly etc. Against these diseases and pests, the application of fungicides and insecticides can be necessary.

The first fertilisation of 50-70 kg ha<sup>-1</sup> (65) nitrogen is recommended during the spring; later in the year another fertilisation of 30-50 kg ha<sup>-1</sup> (35) is recommended. The second fertilisation is necessary to improve the quality of the harvested crop, especially for food production. Crops planted for energy need a lower protein rate and can therefore be fertilised less in the second application. Other fertilisers are magnesium 12 kg ha<sup>-1</sup>, potassium 80 kg ha<sup>-1</sup> and phosphorus 28 kg ha<sup>-1</sup>.

Winter wheat has an average yield of about 5.2 t ha<sup>-1</sup> (grain). The yield of the whole crop is about 10 t ha<sup>-1</sup>.

### **Crop rotation**

Winter wheat should be planted in crop rotation, but not after cereal crops. Seeding it into stubble from broad-leaved crops, such as canola, mustard and peas, will reduce the risk of insect, disease and weed problems for all crops in the rotation.

### **Regional aspects**

Differences result from ecological requirements and different yields.

### **Outlook**

It is assumed that the development of agriculture will not lead to other yields than today in the EU 15 and new EU countries.

## Provision chains

### Treatment

Once the cereal plant has grown its seeds, it has completed its life cycle. The plants die and become brown and dry. As soon as the parent plants and their seed kernels are dry, harvest can begin.

In developed countries cereal crops are machine-harvested, typically using a combine harvester, which cuts, threshes, and winnows the grain during a single pass across the field.

### Storage

The dry grain can be stored easily, i.e. in large storage facilities (grain elevators) that consolidate the crops of many farmers or in smaller storage tanks.

If a crop is harvested during wet weather, the grain may not dry adequately in the field to prevent spoilage during its storage. In this case, the grain is sent to a dehydrating facility, where artificial heat dries it.

### Transportation

Delivery of grain is possible in transportation devices like trucks, ships or trains that assure the quality of the grain.

The **whole plant** can be used, when planting wheat for energy. Cutting and baling the crop are steps of treatment in this provision chain. The stalk stock **bales** can be burnt in adapted combustion plants to produce heat or steam. The storage of bales is more difficult and the transportable distances are much smaller compared to the use of the grain.

## Sources

- (1) <http://www.agric.gov.ab.ca/agdex/100/12000221.html>.
- (2) <http://www.stichnoth.net/rapool/rapool.cfm?aktland=5>.
- (3) Reinhardt, G., Zemanek, G. (2000): Ökobilanz Bioenergieträger, Erich Schmidt Verlag, Berlin, 2000.
- (4) Statistisches Jahrbuch über Ernährung, Landwirtschaft und Forsten 2001, Münster 2001.
- (5) Kaltschmitt, M., Hartmann, H. (2001): Energie aus Biomasse, Springer Verlag, Berlin,..., 2001.
- (6) Reinhardt, G., Kaltschmitt, M. (1997): Nachwachsende Energieträger, Vieweg Verlag, Braunschweig / Wiesbaden, 1997.
- (7) <http://www.ileia.org/2/16-4/13.PDF>.



<b>Module</b>	<b>P7</b>	<b>Winter rye cultivation</b>
<b>General description of the process, regional aspects, outlook</b>		

Rye (*Secale cereale*) is a grass grown extensively as a grain and forage crop. It is a member of the wheat family and is closely related to barley and wheat, although it is the singular species in the genus *Secale*. Rye grain is used to make flour, feed, some whiskeys and most vodkas. Rye is planted as a livestock forage or harvested for hay, also there is the possibility to regenerate fuel from the grains. The whole crop can be used in combustion systems or as a co-substrate to produce biogas in biogas plants.

### Agronomic requirements

Winter rye is highly tolerant of soil acidity and is more tolerant of dry and cool conditions than wheat. It can withstand hard freezing periods (up to  $-25\text{ }^{\circ}\text{C}$ ) but does not like thick, long lasting layers of snow during winter.

### Crop management

Winter rye is normally sown (seeds:  $160\text{-}240\text{ kg ha}^{-1}$ ) in late September till October and can germinate under cool conditions before going dormant in winter. The seed should be planted at a depth 2-3 cm, not any deeper, onto a consolidated seedbed (soil contact), the distance between the rows should be at least 10-12 cm. The desired density of spears is around  $450\text{ spears m}^{-2}$ . After the frost periods in January or later, rolling might be necessary, to improve the contact to the soil. The plants develop quickly and can overgrow bad weeds. Rye is finally harvested in July-August at the stadium of ripeness. Outgrowth of the grain at the spear can appear in harvest time, especially in laying stocks. Several diseases and pests have been known, e.g. fusarium, mildew, fly etc. Against these diseases and pests, the application of fungicides and insecticides can be necessary.

The fertilisation of  $40\text{ kg ha}^{-1}$  nitrogen is recommended during early spring, later in the year another fertilisation of  $20\text{-}30\text{ kg ha}^{-1}$  is recommended. Other fertilisers are potassium  $85\text{ kg ha}^{-1}$  and phosphorus  $30\text{ kg ha}^{-1}$ .

Winter rye has an average yield of about  $3.1\text{ t ha}^{-1}$  (grain). The yield of the whole crop is about  $6\text{ t ha}^{-1}$ .

### Crop rotation

Since rye is self-tolerating it does not necessarily require crop rotation. It can be included into cereal crop rotation to reduce diseases and pests or any other crop rotation plan easily.

### Regional aspects

Rye is widely cultivated in Central and Eastern Europe and is the main bread cereal in most areas east of the French-German border and north of Hungary. Differences result from ecological requirements and different yields.

### Outlook

It is assumed that the development of agriculture will not lead to increased yields in the EU 15 and new EU countries.

## Provision chains

### Treatment

Once the cereal plant has grown its seeds, it has completed its life cycle. The plants die and become brown and dry. As soon as the parent plants and their seed kernels are dry, harvest must begin. It is important to avoid outgrowth of the grain, which seriously reduces the quality of the flour.

In developed countries, cereal crops are universally machine-harvested, typically using a combine harvester, which cuts, threshes, and winnows the grain during a single pass across the field.

### Storage

The dry grain can be stored easily, i.e. in large storage facilities (grain elevators) that consolidate the crops of many farmers or in smaller storage tanks.

If a crop is harvested during wet weather, the grain may not dry adequately in the field to prevent spoilage during its storage. In this case, the grain is sent to a dehydrating facility, where artificial heat dries it.

### Transportation

Delivery of grain is possible in transportation devices like trucks, ships or trains that assure the quality of the grain.

The **whole plant** can be used, when planting rye on energy purpose. Cutting and baling the crop are steps of treatment in this provision chain. The stalk stock **bales** can be burnt in adapted combustion plants to produce heat or steam. The storage of bales is more difficult and the transportable distances are much smaller compared to the use of the grain.

## Sources

- (1) [eesc.orst.edu/AgComWebFile/EdMat/EM8692.pdf](http://eesc.orst.edu/AgComWebFile/EdMat/EM8692.pdf).
- (2) <http://www.stichnoth.net/rapool/rapool.cfm?aktland=5>.
- (3) Reinhardt, G., Zemanek, G. (2000): Ökobilanz Bioenergieträger, Erich Schmidt Verlag, Berlin, 2000.
- (4) Statistisches Jahrbuch über Ernährung, Landwirtschaft und Forsten 2001, Münster 2001.
- (5) Kaltschmitt, M., Hartmann, H. (2001): Energie aus Biomasse, Springer Verlag, Berlin, ..., 2001.
- (6) Reinhardt, G., Kaltschmitt, M. (1997): Nachwachsende Energieträger, Vieweg Verlag, Braunschweig / Wiesbaden, 1997.- "Energie aus Biomasse" Kaltschmitt/Hartmann Springer Verlag 2001.
- (7) Die Landwirtschaft, Band 1: Pflanzliche Erzeugung, BLV Verlagsgesellschaft München, Landwirtschaftsverlag Münster-Hiltrup, 1998, München.



Module	P8	Barley cultivation
<b>General description of the process, regional aspects, outlook</b>		

Barley (*Hordeum vulgare*) is a major food and animal feed crop, a member of the grass family *Poaceae*. Barley is the fifth largest cultivated cereal crop in the world. Its cultivation has a long tradition. It is planted as a livestock forage or used as malting barley, a key ingredient in beer and whiskey production. Also there is the possibility to regenerate fuel from the grains. The whole crop can be used in combustion systems or as a co-substrate to produce biogas in biogas plants.

### Agronomic requirements

Barley is widely adaptable and is currently a major crop of the temperate and tropical areas. It is more tolerant of salts than wheat. Barley can still thrive in conditions that are too cold even for rye.

### Crop management

Winter barley has a long vegetation period and is therefore normally sown in mid September. It can germinate under cool conditions before going dormant in winter. The seed should be planted at a depth of 4-5 cm, onto a consolidated seedbed (soil contact), the distance between the rows should be around 8-12 cm. The desired seed density is around 300–400 seeds m<sup>-2</sup> (about 180 kg ha<sup>-1</sup>). After the frost periods in January or later, rolling might be necessary, to improve the contact to the soil. Barley is harvested late at the stage of threshing ripeness. Several diseases and pests have been known, e.g. fusarium, mildew, fly etc. Against these diseases and pests, the application of fungicides and insecticides can be necessary.

The fertilisation of 50-60 kg ha<sup>-1</sup> (55) nitrogen is recommended during early spring, later another fertilisation of 30-40 kg ha<sup>-1</sup> (30) is recommended. Other fertilisers are potassium 80 kg ha<sup>-1</sup> and phosphorus 30 kg ha<sup>-1</sup>.

Barley has an average yield of about 4.2 t ha<sup>-1</sup> (grain). The yield of the whole crop is about 6 t ha<sup>-1</sup>.

### Crop rotation

Barley is chiefly grown after turnips, sometimes after peas and beans, but rarely after wheat or oats.

### Regional aspects

Differences result from ecological requirements and different yields.

### Outlook

It is assumed that the development of agriculture will not lead to increased yields in the EU 15 and new EU countries.



## Provision chains

### Treatment

Once the cereal plant has grown its seeds, it has completed its life cycle. The plants die and become brown and dry. As soon as the parent plants and their seed kernels are dry, harvest can begin.

In developed countries, cereal crops are usually machine-harvested, typically using a combine harvester, which cuts, threshes, and winnows the grain during a single pass across the field.

### Storage

The dry grain can be stored easily, i.e. in large storage facilities (grain elevators) that consolidate the crops of many farmers or in smaller storage tanks.

If a crop is harvested during wet weather, the grain may not dry adequately in the field to prevent spoilage during its storage. In this case, the grain is sent to a dehydrating facility, where artificial heat dries it.

### Transportation

Delivery of grain is possible in transportation devices like trucks, ships or trains that maintain the grain quality.

The **whole plant** can be used, when planting barley for energy. Cutting and baling the crop are steps of treatment in this provision chain. The stalk stock **bales** can be burnt in adapted combustion plants to produce heat or steam. The storage of bales is more difficult and the transportable distances are much smaller compared to the grain.

## Sources

- (1) [eesc.orst.edu/AgComWebFile/EdMat/EM8692.pdf](http://eesc.orst.edu/AgComWebFile/EdMat/EM8692.pdf).
- (2) <http://www.stichnoth.net/rapool/rapool.cfm?aktland=5>.
- (3) Reinhardt, G., Zemanek, G. (2000): Ökobilanz Bioenergieträger, Erich Schmidt Verlag, Berlin, 2000.
- (4) Statistisches Jahrbuch über Ernährung, Landwirtschaft und Forsten 2001, Münster 2001.
- (5) Kaltschmitt, M., Hartmann, H. (2001): Energie aus Biomasse, Springer Verlag, Berlin,..., 2001.
- (6) Reinhardt, G., Kaltschmitt, M. (1997): Nachwachsende Energieträger, Vieweg Verlag, Braunschweig / Wiesbaden, 1997: "Energie aus Biomasse" Kaltschmitt/Hartmann Springer Verlag 2001.
- (7) Die Landwirtschaft, Band 1: Pflanzliche Erzeugung, BLV Verlagsgesellschaft München, Landwirtschaftsverlag Münster-Hiltrup, 1998, München.



Module	P9	Triticale cultivation
<b>General description of the process, regional aspects, outlook</b>		

Triticale is the secondary amphiploids of durum wheat and rye. Durum wheat, the donor of the A and B genomes, is known for its high yield potential and adaptation to relatively dry environments. On the other hand, rye, the R genome donor, has lower yield potential but is well adapted to extreme cold, drought, and acidic soils. Triticale cultivation around the world during the last 25 years indicates that it possesses the yield potential of wheat and the hardiness of rye. The yield potential of triticale under optimum crop production environments has reached the level of wheat while outperforming wheat in marginal environments. The plants vegetation period is about 330 days (September-July).

The grain is mainly used for forage and feed, but also for unleavened bakery products. Also there is the possibility to regenerate fuel from the grains. The whole crop can be used in combustion systems or as a co-substrate to produce biogas in biogas plants.

### **Agronomic requirements**

It can grow in almost all geographic ranges, but with increasing soil quality the yields rise. Due to the high climatically adaptability of the plant, triticale can also build up in rougher exposures a sufficient stand density.

### **Crop management**

Triticale is normally sown in September-October and grows just a little before going dormant in winter. The seed should be planted at a depth 2-4 cm, the distance between the rows should be 12-20 cm. The desired crop density is between 250-380 plants m<sup>-2</sup>. Therefore, 140-180 kg ha<sup>-1</sup> of seeds are needed. After the floral initiation in January, the plants develop a number of tillers and are finally harvested in July-August. The weed combat is possible in mechanical or chemical ways. Several diseases and pests have been known, e.g. fusarium, mildew, fly etc. Against these diseases and pests, the application of fungicides and insecticides can be necessary.

The fertilisation of 40-60 kg ha<sup>-1</sup> (55) nitrogen is recommended during the spring, later another fertilisation of 20-30 kg ha<sup>-1</sup> (20) is recommended. Other fertilisers are magnesium 9 kg ha<sup>-1</sup>, potassium 85 kg ha<sup>-1</sup> and phosphorus 30 kg ha<sup>-1</sup>.

Triticale has an average yield of about 4.2 t ha<sup>-1</sup> (grain). The yield of the whole crop is about 10-12 t ha<sup>-1</sup>.

### **Crop rotation**

Triticale should be planted in crop rotation, but not after cereal crops. Seeding it into stubble from broad-leaved crops, such as canola, mustard and peas, will reduce the risk of insect, disease and weed problems for all crops in the rotation.

### **Regional aspects**

Yields differ according to climatic conditions.

## Outlook

It is assumed that the development of agriculture will not lead to other yields than today in the EU 15 and new EU countries.

### Provision chains

#### Treatment

Once the cereal plant has grown its seeds, it has completed its life cycle. The plants die and become brown and dry. As soon as the parent plants and their seed kernels are dry, harvest can begin.

In developed countries, cereal crops are universally machine-harvested, typically using a combine harvester, which cuts, threshes, and winnows the grain during a single pass across the field.

#### Storage

The dry grain can be stored easily, i.e. in large storage facilities (grain elevators) that consolidate the crops of many farmers or in smaller storage tanks.

If a crop is harvested during wet weather, the grain may not dry adequately in the field to prevent spoilage during its storage. In this case, the grain is sent to a dehydrating facility, where artificial heat dries it.

#### Transportation

Delivery of grain is possible in transportation devices like trucks, ships or trains that maintain grain quality.

The **whole plant** can be used, when planting triticale for energy. Cutting and baling the crop are steps of treatment in this provision chain. The stalk stock **bales** can be burnt in adapted combustion plants to produce heat or steam. The storage of bales is more difficult and the transportable distances are much smaller compared to the use of the grain.

### Sources

- (1) [eesc.orst.edu/AgComWebFile/EdMat/EM8692.pdf](http://eesc.orst.edu/AgComWebFile/EdMat/EM8692.pdf)
- (2) <http://www.stichnoth.net/rapool/rapool.cfm?aktland=5>.
- (3) Reinhardt, G., Zemanek, G. (2000): Ökobilanz Bioenergieträger, Erich Schmidt Verlag, Berlin, 2000.
- (4) Statistisches Jahrbuch über Ernährung, Landwirtschaft und Forsten 2001, Münster 2001.
- (5) Kaltschmitt, M., Hartmann, H. (2001): Energie aus Biomasse, Springer Verlag, Berlin,..., 2001
- (6) Reinhardt, G., Kaltschmitt, M. (1997): Nachwachsende Energieträger, Vieweg Verlag, Braunschweig / Wiesbaden, 1997.- "Energie aus Biomasse" Kaltschmitt/Hartmann Springer Verlag 2001.
- (7) [www.worldbank.org/html/cgiar/newsletter/april97/8tritic.html](http://www.worldbank.org/html/cgiar/newsletter/april97/8tritic.html).



Module	P10	Maize cultivation
<b>General description of the process, regional aspects, outlook</b>		

Maize is an annual C4 plant which originated from America. It is a member of the *Gramineae* family and produces large, narrow, opposing leaves, borne alternately along the length of a solid stem. The plant produces male inflorescences (tassels) which crown the plant at the stem, and female inflorescences (ears) which are borne at the apex of condensed lateral branches protruding from the leaf axis. Each plant produces up to 4 ears. Maize is fertilised by wind-blown pollen. The vegetation period is about 130-180 days (May-September).

Maize has many uses e.g. maize meal, feed for animals, cornflakes etc. Maize has the possibility to regenerate fuel from the grains, the whole crop (as silage) can be used to produce biogas as a main substrate in fermentation processes.

### **Agronomic requirements**

Maize is very self-sufficient and can therefore be grown as a monoculture. The crop, which is produced from 50° latitude N to 40° S, is adapted to deserted and high rainfall environments, and to elevations ranging from 0 to 4,000 meters above sea level.

### **Crop management**

Its demand for warmth during germination and early development (frost-sensitivity) leads to a late sowing from the end of April until mid-May, depending on the region. Depending on the harvesting technology and its use, the distance between the rows is normally 75 cm and the population density 9-13 plants m<sup>-2</sup>. This density is reached with 60 kg ha<sup>-1</sup> of seeds. If no mechanical weed control takes place, the distance between the rows can be reduced to 30 cm. The use of herbicides can be restricted by the use of time limits for food production (permitted periods of time for its application). Young maize plants are especially sensitive to competition between the 4 and 6-leaf-stage. Before and after this time, weeds can be tolerated to a greater degree. Later the maize plants shade the ground very intensively so the growth of weeds is hindered.

For high yield the use of fertilisers is recommended:

nitrogen 160-200 kg ha<sup>-1</sup> (180), phosphorus 35-55 kg ha<sup>-1</sup> (50), potassium 125-170 kg ha<sup>-1</sup> (150), magnesium, 25-30 kg ha<sup>-1</sup>.

Maize has an average yield of about 8 t ha<sup>-1</sup> (grain). The yield of the whole crop (silage) is about 44 t ha<sup>-1</sup>.

### **Crop rotation**

The cultivation of catch crops, before maize is planted, primarily serves to cover the ground through the winter. Depending on the previous crop any hibernating catch crop can be considered. With conservation tillage it is often useful to kill the catch crops and weeds with a non-selective herbicide directly before the sowing of the maize. Catch crops planted after maize should guarantee the reception of remaining nutrients. The need of catch crops during their development can be catered for by sowing them as an underseed in maize. Thereby a higher catch crop mass can still be achieved in comparison to stubble seed in the autumn. The maize is sown into an existing turf with the technique of rotary sowing. The grass cover between the rows is usually kept short with mechanical methods. In addition, the reduction of

the maize share in a crop rotation should be regarded as an important aspect with diverse environmentally relevant effects, above all if it is interconnected with the introduction of other plant cultures.

### **Regional aspects**

Yields differ according to climatic conditions.

### **Outlook**

It is assumed that the development of agriculture will not lead to increased yields in the EU 15 and new EU countries.

<b>Provision chains</b>
-------------------------

Maize used as silage is harvested while the plant is green and the fruit unmaturing. Otherwise, maize is left in the field very late in the autumn in order to dry thoroughly. In fact, it is sometimes not harvested until winter or even early spring.

<b>Sources</b>
----------------

- (1) <http://maize.agron.iastate.edu>.
- (2) [http://europa.eu.int/comm/environment/agriculture/pdf/mais\\_allemande.pdf](http://europa.eu.int/comm/environment/agriculture/pdf/mais_allemande.pdf).
- (3) Reinhardt, G., Zemanek, G. (2000): Ökobilanz Bioenergieträger, Erich Schmidt Verlag, Berlin, 2000.
- (4) Statistisches Jahrbuch über Ernährung, Landwirtschaft und Forsten 2001, Münster 2001.
- (5) Kaltschmitt, M., Hartmann, H. (2001): Energie aus Biomasse, Springer Verlag, Berlin,..., 2001.
- (6) Reinhardt, G., Kaltschmitt, M. (1997): Nachwachsende Energieträger, Vieweg Verlag, Braunschweig / Wiesbaden, 1997.
- (7) <http://www.stichnoth.net/rapool/rapool.cfm?aktland=5>.



<b>Module</b>	<b>P11</b>	<b>Potato cultivation</b>
<b>General description of the process, regional aspects, outlook</b>		

The potato is part of the nightshade family and has its origins in America. The yield organs, the tubers, are generated underground. The aboveground sprout part gives the potato plant a herbal look. The bloom colour varies from white to red or blue. The potato vegetation period is about 140-180 days (April-September). Potatoes have many uses e.g. starch source for food industry, fuel source etc.

### **Agronomic requirements**

Most soils will grow potatoes. For starch potatoes the most appropriate soils are humus rich, loamy sand or sandy loam. The potato loves warm, loose and well-aired soils with good water supply. The soil should be free of stones to prevent the tubers from injury at the harvest. Potatoes will grow under alkaline conditions; the pH range should be between 4.5-7.5. For the formation of tubers a sufficient and consistent water supply is necessary.

### **Crop management**

Planting occurs from late April until early June depending on the weather and soil temperatures. Therefore, machines are used. Ideal soil temperatures to deploy the potatoes are above 7 °C with 70-80 % of available soil water. The potato tubers should be discarded at a depth of 4-6 cm. A crop density of about 40-42 plants m<sup>-2</sup> is appropriated (approx. 2.3 t ha<sup>-1</sup>). Often a combination of mechanical and chemical weed combat is used. Potatoes are strongly endangered by virus infestation. Several disease and pests have been known to attack potato crops e.g. black leg, late blight, rhizoctonia canker and black scurf, potato leafroll virus and grey mould. To prevent diseases and pests, the application of fungicides and/or insecticides may be necessary.

The use of fertiliser for potato plants is recommended: nitrogen 100-150 kg ha<sup>-1</sup> (120), potassium 80-150 kg ha<sup>-1</sup> (120), phosphorus 50 kg ha<sup>-1</sup>, magnesium 40 kg ha<sup>-1</sup>.

Organic fertilisation should be deployed in the autumn.

Potatoes have an average yield of about 26 t ha<sup>-1</sup>.

### **Crop rotation**

Crops coming before the potato plant are cereals and sugar beet, which leave behind a crowd of organic materials in the soil. The break in planting potatoes should be 4-5 years.

### **Regional aspects**

Differences result from ecological requirements and different yields.

### **Outlook**

It is assumed that the development of agriculture will not lead to increased yields in the EU 15 and new EU countries.

## Provision chains

Potatoes are harvested when most of the tops have withered. They can be stored in a dark but dry place to ensure the potatoes do not turn green.

## Sources

- (1) <http://collections.ic.gc.ca/potato>.
- (2) <http://www.stichnoth.net/rapool/rapool.cfm?aktland=5>.
- (3) Reinhardt, G., Zemanek, G. (2000): Ökobilanz Bioenergieträger, Erich Schmidt Verlag, Berlin, 2000.
- (4) Statistisches Jahrbuch über Ernährung, Landwirtschaft und Forsten 2001, Münster 2001.
- (5) Kaltschmitt, M., Hartmann, H. (2001): Energie aus Biomasse, Springer Verlag, Berlin,..., 2001.
- (6) Reinhardt, G., Kaltschmitt, M. (1997): Nachwachsende Energieträger, Vieweg Verlag, Braunschweig / Wiesbaden, 1997.



<b>Module</b>	<b>P12</b>	<b>Sweet sorghum cultivation</b>
<b>General description of the process, regional aspects, outlook</b>		

Sweet sorghum has its origin in North-East Africa. The plant possesses a number of special characteristics when compared with other cereal species. It is an annual C4 herbaceous plant and at a height of 10-15 cm it produces tillering sprouts. The plant also forms a strong root system. Because of its pith filled stems, which grow to a height of up to 5 m, the appearance of the plant is reminiscent of maize. On opposite sides of the stalk at the nodes alternate a leaf and a lateral bud. The leaves have a waxy or glossy smooth surface. Sweet sorghum is self-pollinating. The inflorescence is a compact panicle containing 1000-5000 flowers. The inflorescence may be upright or pendant. For high performance varieties it is essential that the panicle is upright.

Like sugar beet it can be used for fuel production in fermentation processes.

### **Agronomic requirements**

Sweet sorghum is a short-day plant. However, other forms having modified photoperiodic requirements also exist. Presently, all species of sweet sorghum are sensitive to frost, with low temperatures being the main limiting factor in productivity in middle and northern Europe. The minimum temperatures tolerated are between 7 and 10 °C. The optimum growing temperature is in the range from 27-30 °C. Sweet sorghum grows well in those areas where the annual precipitation does not fall below 350-450 mm. The plants react very positively to additional irrigation.

The extremely well-developed ability of sweet sorghum to tolerate drought is due to the high efficiency of its root system, the activity of which is twice as high as that in maize.

Because of its great ability to take up minerals, its soil requirements are very modest. Sweet sorghum tolerates salts and alkalis and flourishes in a pH range of 5.0-8.5. Although acidic soils are not normally suitable, some varieties of sorghum exhibit a well-developed tolerance to acidic conditions.

### **Crop management**

For preparing the seedbed a ploughing depth of 10-15 cm is suggested, with the seeds being planted at a depth of 2-4 cm. Pre-emergence herbicide application is recommended. The sowing date is dependent on the climate of the region. Approximately 15 kg ha<sup>-1</sup> of seeds are used. Climates similar to the Po Valley in northern Italy will have the best sowing dates in the second half of April. Here tests have also shown that row distances of 70 cm apart and a plant density of 7-8 plants m<sup>-2</sup> are favoured. In northern Germany sowing is best done in May, with a distance between rows of 40-50 cm and a plant number of 16-18 plants m<sup>-2</sup>. Because of its sensitivity to frost it is necessary in northern Europe to use sweet sorghum varieties with a shorter growth season, less than 6 months.

The various forms of sweet sorghum sprout 10-16 days after sowing. After a slow developmental phase, the plants exhibit a large growth spurt in the first half of July. Though sweet sorghum crops grow well at low levels of precipitation, levels less than 500 mm per year warrant crop irrigation. Sweet sorghum experiments under Mediterranean conditions showed that the crop had water requirements quite similar to the normal Mediterranean crops, yet higher dry matter yield.



Fertiliser recommendations as used in Germany: nitrogen 140-160 kg ha<sup>-1</sup>, potassium 200-240 kg ha<sup>-1</sup>, phosphorus 120-140 kg ha<sup>-1</sup>.

Sweet sorghum is affected by a host of diseases and insect pests. Several basic measures can be taken to protect against disease and insect: sufficient rotation, use of resistant cultivars, seed treatment and weeding.

Sweet sorghum has an average yield of about 25 t ha<sup>-1</sup> (entire plant).

### **Crop rotation**

Sorghum can be handled the same as maize concerning crop rotation. It is also able to follow itself in the rotation. The only caution is that maize should not be planted before or after sweet sorghum.

### **Regional aspects**

Yields differ according to climatic conditions.

### **Outlook**

It is assumed that the development of agriculture will not lead to increased yields in the EU 15 and new EU countries.

### **Provision chains**

The optimal harvesting time is between mid October and mid November. This allows for maximum sugar yield, yet harvest is before the onset of snowing and freezing. In choosing a harvester several factors should be taken into consideration. Since the sugar begins to ferment when it comes into contact with air, it is important that the stalks are cut as few times as possible and low enough at the base. Also the harvester needs to be able to remove the leaves and panicles from the stalks.

Storage duration depends on how the crop was handled. Whole plants can be stored for approximately 27 days outside, billets 25-40 cm can be stored 19 days, 10 cm billets can be stored 12 days, and chopped sweet sorghum should be processed directly following harvest.

### **Sources**

- (1) <http://www.stichnoth.net/rapool/rapool.cfm?aktland=5>.
- (2) Reinhardt, G., Zemanek, G. (2000): Ökobilanz Bioenergieträger, Erich Schmidt Verlag, Berlin, 2000.
- (3) Statistisches Jahrbuch über Ernährung, Landwirtschaft und Forsten 2001, Münster 2001.
- (4) Kaltschmitt, M., Hartmann, H. (2001): Energie aus Biomasse, Springer Verlag, Berlin, ..., 2001.
- (5) Reinhardt, G., Kaltschmitt, M. (1997): Nachwachsende Energieträger, Vieweg Verlag, Braunschweig / Wiesbaden, 1997.



<b>Module</b>	<b>P13</b>	<b>Hemp cultivation</b>
<b>General description of the process, regional aspects, outlook</b>		

Hemp has its origins in Central Asia. It is an annual, short-day, C3 plant which is wind pollinated. It has a high cellulose and lignin content in its stems and a high fat and protein content in its seeds. The average height is about 2.5 m. The leaves are finger-like with serrated edges. The root system is dominated by a tap root. The plants vegetative period is about 100 days, with the main growth period in June and July, followed by flowering in August. Due to the presence of tetrahydrocannabinol (THC) the cultivation of hemp is difficult. For THC to be used as a drug it needs to be present in an amount of over 2 %. Because of this an EU regulation makes it possible to cultivate hemp varieties with THC contents of 0.3 % or less.

Hemp has many uses e.g. textile industry, fuel, machine oil and cosmetics. The whole crop can be used in combustion systems.

### **Agronomic requirements**

Hemp exhibits optimal growth in a moderate climate, 13-22 °C. Hemp is sensitive to frost during germination. Though the crop thrives on most soils, it prefers deep, humus rich, calcareous soils with a good water and nitrogen supply. Not as suitable are sand, heavy clay and excessively wet soils, as well as compacted soils. A pH value of 7 is recommended, though slightly basic soils are also appropriate. The soil should be well prepared to a fine tilth. The soil should be well supplied with water, but not excessively wet. A precipitation level of 700 mm is necessary for a substantial yield.

### **Crop management**

Sowing should be performed between the middle of April and the end of May. Approximately 35-50 kg ha<sup>-1</sup> of seed should be planted at a depth of 2-4 cm. A normal crop density is about 200-250 plants m<sup>-2</sup>. A higher crop density, about 300 plants m<sup>-2</sup>, is used if the crop is grown for the production of long fibres. The higher density leads to a reduced production of undesired leaves. The seed has a germination period of 4-6 days. Herbicides may not even be necessary. Farms in the UK report that after drilling the seed there is no need for spraying or top-dressing. The next time the crop is regarded will be for checking its progress. Several diseases and pests have been known to attack hemp crops. The detrimental presence of *botrytis*, *fusarium* and *sclerotinia* has been observed, along with damage to germinating plants by snails and wireworms. The plant fibres may suffer damage from *Spherella cannabis* and *Phoma herbarum*.

Fertiliser levels as recommended by the Federal Agricultural Research Centre in Germany are:

nitrogen      60-100 kg ha<sup>-1</sup>, (divided in two or three applications)

phosphorus    70-100 kg ha<sup>-1</sup>,

potassium     150-180 kg ha<sup>-1</sup> (fertilisation rates depend on the environmental conditions).

Research in Germany showed results on whole plant dry matter yields of 8-16 t ha<sup>-1</sup> (10) and fibre yields of 2-4 t ha<sup>-1</sup> (3). A typical hemp harvest consists of 52 % usable refuse, 31 % fibre (40 % long and 60 % short), 9 % non-usable refuse and 8 % seeds.

### **Crop rotation**

Because of its deep and extensive root system, hemp makes a good preceding crop in a crop rotation. In the UK a crop rotation of wheat and hemp has proved to be appropriate. Hemp can also follow itself in a crop rotation.

### **Regional aspects**

Differences result from ecological requirements and different yields.

### **Outlook**

It is assumed that the development of agriculture will not lead to increased yields in the EU 15 and new EU countries.

<b>Provision chains</b>
-------------------------

Harvesting takes place in September depending on the variety planted and its intended use. Mechanical harvesting is now common, using specially adapted cutter-binders or simpler cutters. The cut hemp is laid in swathes to dry for up to four days. This was traditionally followed by retting, either water retting whereby the bundled hemp floats in water or dew retting whereby the hemp remains on the ground and is affected by the moisture in dew moisture, and by moulds and bacterial action. Modern processes use steam and machinery to separate the fibre, a process known as thermo-mechanical pulping.

<b>Sources</b>
----------------

- (1) [www.fao.org/regional/europe/escorena/b46/cover.pdf](http://www.fao.org/regional/europe/escorena/b46/cover.pdf) "RENEWABLE ENERGY- Potential energy crops for Europe and the Mediterranean region" Regional Office For Europe (REU).
- (2) Federal Agricultural Research Centre (FAL) Braunschweig, Germany.
- (3) Reinhardt, G., Zemanek, G. (2000): Ökobilanz Bioenergieträger, Erich Schmidt Verlag, Berlin, 2000.
- (4) Statistisches Jahrbuch über Ernährung, Landwirtschaft und Forsten 2001, Münster 2001.
- (5) Kaltschmitt, M., Hartmann, H. (2001): Energie aus Biomasse, Springer Verlag, Berlin, ..., 2001.
- (6) Reinhardt, G., Kaltschmitt, M. (1997): Nachwachsende Energieträger, Vieweg Verlag, Braunschweig / Wiesbaden, 1997.
- (7) <http://www.verbraucherministerium.de/landwirtschaft/ab-2001/ab01/textband/tb-cl.htm>.



<b>Module</b>	<b>P14</b>	<b>Miscanthus cultivation</b>
<b>General description of the process, regional aspects, outlook</b>		

Miscanthus is a genus of woody, perennial, tufted or rhizomatous grasses which is related to sugar cane. It is high in lignin and lignocelluloses fibre and uses the C4 photosynthetic pathway. The erect stems are slim, yet vigorous and are not usually branched. The solid pith stems are approximately 10 mm in diameter and can reach a height of a little over 2 m the first year and up to 4 m each consecutive year. The herbaceous leaves are usually cauline, flat and linear with a basal tuft which is only weakly developed. The flowers are arranged on the stem in abundant racemes which lie along a central axis. The rhizomes make up a highly branched storage system. The main goal for the utilisation of miscanthus is whole plant compaction to produce a solid fuel, with gasification as a large-scale option.

### **Agronomic requirements**

The growing season temperature has a large effect on crop yield of miscanthus. Though the crop prefers warmer climates it has been shown that miscanthus can be grown with favourable results throughout Europe. Miscanthus has evolved in regions of the world that have large temperature fluctuations between summer and winter. Miscanthus does not have many demands on the soil, this being demonstrated by its ability to grow on many types of arable land. To establish the crop in April or May it is necessary that the soil is sufficiently aerated and has a fine tilth, thus making soils of greater than 25 % clay probably unsuitable. Soil with 70-95 mm of available water per 500 mm depth is recommended for miscanthus. During the crop's growing season it is estimated that 600 mm of precipitation is necessary to produce sufficient yields. Data from Denmark and the UK suggest that the optimum pH range is between 5.5 and 7.5 for growing miscanthus. This excludes soils that are very acidic or very chalky from the possibilities for optimum miscanthus growth.

### **Crop management**

It is recommended that young plants and stored rhizomes are planted when the planting depth temperature of the soil is 10 °C or greater. This corresponds to approximately late April to early June. The important factors are: sufficient soil moisture, fine tilth and avoidance of young plant destruction from frost. The suggested spacings from Germany are 0.7-1.0 m between plants and 0.8-1.0 m between rows. This corresponds to approx. 10,000 plants ha<sup>-1</sup>. Though new shoots are quick to emerge after planting, the period of time until May or June is marked by slow growth. With the more favourable temperatures of summer comes rapid growth, with development of stalks over 2 m in the first year and 4 m the following years. Weed control is an important factor especially during the establishment and first two years of the crop. The best time for nutrient application is in the spring, before the new growth season, but after the previous harvest:

nitrogen 50 kg ha<sup>-1</sup>, potassium 45 kg ha<sup>-1</sup>, phosphorus 21 kg ha<sup>-1</sup>, sulphur 25 kg ha<sup>-1</sup>, magnesium 13 kg ha<sup>-1</sup>, calcium 25 kg ha<sup>-1</sup> are recommended.

11 tons per year and hectare have been assumed for the most important countries in the temperate climate zone. In literature, yield data between 3-30 t ha<sup>-1</sup> per year have been published (dry matter, entire plant).

### **Crop rotation**

Because miscanthus is a perennial crop, a crop rotation may not be necessary for more than 15 years. This possibility makes it important that the field is cleared of all perennial weeds before cultivation.

### **Regional aspects**

Differences result from ecological requirements and different yields.

### **Outlook**

It is probable that a higher yield can be achieved in the long-term, as more experience with miscanthus cultivation is gained.

<b>Provision chains</b>
-------------------------

Harvesting of miscanthus is performed in February/March. This is the time of highest dry matter content: up to 80 %, can be achieved and much of the nutrients have been sequestered in the rhizomes. The use of machinery for harvesting must be done carefully so as to limit compaction and damage to the underlying rhizome bed. Currently, mechanical harvesters are being studied to determine what form of machinery will work best.

Several general handling methods are presently seen as possible: pelleting, briquetting, baling and wafering. Drying and storage are possible, but at this time have been the focus of little research. It is believed that after harvest the product can be either covered and left outside, moved to a storage facility, or the excess heat from combustion of already dry crop matter can be used for crop drying, leading to long term storage.

<b>Sources</b>
----------------

- (1) [www.fao.org/regional/europe/escorena/b46/cover.pdf](http://www.fao.org/regional/europe/escorena/b46/cover.pdf) "RENEWABLE ENERGY-Potential energy crops for Europe and the Mediterranean region" Regional Office For Europe (REU).
- (2) Federal Agricultural Research Centre (FAL) Braunschweig, Germany.
- (3) Reinhardt, G., Zemanek, G. (2000): Ökobilanz Bioenergieträger, Erich Schmidt Verlag, Berlin, 2000.
- (4) Statistisches Jahrbuch über Ernährung, Landwirtschaft und Forsten 2001, Münster 2001.
- (5) Kaltschmitt, M., Hartmann, H. (2001): Energie aus Biomasse, Springer Verlag, Berlin,..., 2001.
- (6) Reinhardt, G., Kaltschmitt, M. (1997): Nachwachsende Energieträger, Vieweg Verlag, Braunschweig / Wiesbaden, 1997.
- (7) <http://www.miscanthus.de/verwertung.htm>.



<b>Module</b>	<b>P15</b>	<b>Willow cultivation</b>
<b>General description of the process, regional aspects, outlook</b>		

A typical species for a fast growing tree is the willow. The willow is a member of the *Salicales* family. Their geographical origin (mainly UK, Germany and Scandinavia) and parental species are documented, but their precise parental provenance is not known. Willow possesses longish shaped leaves. In the first year the trunk has only one shoot, but in the second year many ramifications are generated. The twigs of the willow are used for rough wickerwork, fascines and fences. The bark has been employed for tanning purposes and as a salicin-containing drug. The wood chips can be used for energy purpose in combustion systems or be processed to fuel in adapted fermentation applications.

### **Agronomic requirements**

Ecologically sensitive areas such as heathlands, chalk downs, high moorland grazing, coastal dunes or estuarine margins are not suited to willow crops and are not likely to be planted. Commonly perceived as a species adapted to riverbanks, wetland or even bogs, willows, although tolerant of a degree of waterlogging, are not constrained to these sites, and can be grown successfully on a wide range of soil types. However, willows will not produce economically viable yields on very dry or alkaline soils. In general, sites considered as marginal for conventional agronomy, for instance, because of excessive winter waterlogging, will suit the willow. A rule of thumb in selecting willow sites might be those areas of a farm currently agriculturally less productive, which would be the first choice for permanent set-aside. The water requirement of willows has been estimated at 600 mm precipitation.

### **Crop management**

For ease of planting, successful rooting and subsequent management, the site should be subsoiled if necessary, deep (250-300 mm) ploughed in autumn and then power-harrowed to produce a level, uncompacted tilth. The main determinants are suitable soil conditions and, in extremis, planting may be delayed to May, though with an increasing risk of losses due to drought. Northern or southern areas of Europe would need to adjust planting time to similar appropriate periods. Planting stock consists of about 15,000 unrooted cuttings per hectare from maiden (one-year-old) stems, 200-250 mm long and not less than 8 mm top diameter. A crop density of 10 plants m<sup>-2</sup> are recommended. Weed control in newly planted willows is important, otherwise the height growth can be reduced to 50 %. The willow may be attacked by a wide range of leaf eating, stem-sucking and wood-boring insect pests, but none has so far been more than an occasionally serious problem. Natural enemies and the immense number of leaves on a 1-3 year-old crop should ensure that normal levels of insect attack are not seriously damaging. The most serious disease is rust, caused by species of *Melampsora*. The following fertilisers are recommended:

nitrogen 60 kg ha<sup>-1</sup>, phosphorus 15 kg ha<sup>-1</sup> potassium 35 kg ha<sup>-1</sup>, lime 18 kg ha<sup>-1</sup>, magnesium 3 kg ha<sup>-1</sup>.

Willow has an average yield of about 10 t ha<sup>-1</sup> (entire plant) per year.

## Crop rotation

Because willow is a perennial crop, a crop rotation may not be necessary for more than 15 years. The species chosen for short rotation coppice (SRC) have, in common, the ability to make extremely rapid growth for the first few years following coppicing, with consequent very high yields. The optimum harvest interval is that which gives the highest yield of the most useable material for the least cost and easiest cutting/chipping operations. In practice, the best compromise between maximising yield and minimising harvesting costs - at least for energy use - is likely to be around 3-4 years.

## Regional aspects

Yields differ according to climatic conditions.

## Outlook

It is assumed that the development of fertilised SRC will not lead to similar yields in the EU 15 countries and that it will lead to similar yields in the new member countries like in the EU 15.

## Provision chains

Cutting and chipping is carried out in one operation by purpose-built or - more usually - modified conventional agronomic machines, such as forage harvesters. These typically require around one hour to harvest and chip each hectare. The wet (50 % moisture) chips produced would very quickly deteriorate by microbial activity if they were simply heaped on hard standing, so they must be ventilated for storage.

Harvesting can be done at any time between leaf fall and bud-burst. In the UK this is usually between mid-November and mid-March, but can vary considerably both with season and species.

## Sources

- (1) [www.fao.org/regional/europe/escorena/b46/cover.pdf](http://www.fao.org/regional/europe/escorena/b46/cover.pdf) "RENEWABLE ENERGY-Potential energy crops for Europe and the Mediterranean region" Regional Office For Europe (REU).
- (2) Federal Agricultural Research Centre (FAL) Braunschweig, Germany.
- (3) Reinhardt, G., Zemanek, G. (2000): Ökobilanz Bioenergieträger, Erich Schmidt Verlag, Berlin, 2000.
- (4) Statistisches Jahrbuch über Ernährung, Landwirtschaft und Forsten 2001, Münster 2001.
- (5) Kaltschmitt, M., Hartmann, H. (2001): Energie aus Biomasse, Springer Verlag, Berlin,..., 2001.
- (6) Reinhardt, G., Kaltschmitt, M. (1997): Nachwachsende Energieträger, Vieweg Verlag, Braunschweig / Wiesbaden, 1997.
- (7) [www.dainet.de/fnr/veroff/schnellwbaeume.pdf](http://www.dainet.de/fnr/veroff/schnellwbaeume.pdf).



<b>Module</b>	<b>P15</b>	<b>Poplar cultivation</b>
<b>General description of the process, regional aspects, outlook</b>		

Populus is a genus of trees which includes the cottonwoods, poplars, and aspens, all of which are sometimes termed poplars. Poplars are deciduous, and the leaves of many poplars, including the cottonwoods and aspens (but not the balsam poplars), have laterally-flattened stems. Like willows, many poplars have very strong and invasive root systems. Poplars of the cottonwood section are often wetlands or riparian trees. The aspens are among the most important boreal broadleaf trees.

Poplars can be planted in short rotation coppice (SRC) like willow, at a high density and harvested on a three to four year rotation. The wood chips can be used for energy purpose in combustion systems or be processed to fuel in adapted fermentation applications.

### **Agronomic requirements**

Land preparation prior to planting is similar to that for crops such as wheat and barley. Poplar can be grown on land ranging from currently farmed arable land, through grassland to reclaimed colliery spoil or sand and gravel workings.

### **Crop management**

Weed control is of critical importance in the successful establishment of poplar SRC. It should be undertaken in late summer/early autumn prior to planting and should eradicate all perennial weeds and control all annual weeds present within the site. If weeds were present within the growing crop they would compete for moisture, nutrients, light and space and crop yields would suffer. Where necessary lime addition may be required to bring the soil pH into the range 5.5-8. Sub-soiling may be necessary where compaction is present deep in the soil to allow the roots to develop correctly. Where large stones and other debris are present, they must be removed to prevent damage to machinery. Ploughing should ideally take place before the first winter frost and power harrowing should be undertaken shortly before planting. Rabbit fencing will be necessary at most sites otherwise the young crop would be decimated by rabbits feeding on the emerging shoots.

Planting takes place during the spring typically using a 4 row Step Planter. About 15,000 cuttings, each about 20 cm long, are planted per hectare in double rows. Pre-emergence spraying is carried out shortly after planting to control annual weeds. Good practice dictates that varieties of different poplars should be planted in a mix at each site.

Following the first year's growth, where 2 or 3 shoots will grow from each cutting, the stems are cut back to ground level to encourage the true coppice i.e. multiple stems from each rootstock. Poplars may be attacked by a wide range of leaf eating, stemsucking and wood-boring insect pests, but none has so far been more than an occasionally serious problem. The most serious disease is rust, caused by species of *Melampsora*.

The following fertilisers are recommended: nitrogen 60 kg ha<sup>-1</sup>, phosphorus 15 kg ha<sup>-1</sup>, potassium 35 kg ha<sup>-1</sup>, lime 18 kg ha<sup>-1</sup>, magnesium 3 kg ha<sup>-1</sup>

Poplar has an average yield of about 10 t ha<sup>-1</sup> (entire plant) per year.



### **Crop rotation**

Because poplar is a perennial crop, a crop rotation may not be necessary for more than 15 years. The species chosen for SRC have, in common, the ability to make extremely rapid growth for the first few years following coppicing, with consequent very high yields. The optimum harvest interval is that which gives the highest yield of the most useable material for the least cost and manageable cutting/chipping operations. In practice, the best compromise between maximising yield and minimising harvesting costs - at least for energy use - is likely to be around 3-4 years.

### **Regional aspects**

Differences result from ecological requirements and different yields.

### **Outlook**

It is assumed that the development of fertilised SRC will not lead to other yields than today in the EU 15 countries and that it will lead to comparable yields in the new member countries like in the EU 15.

### **Provision chains**

Cutting and chipping is carried out in one operation by purpose-built or - more usually - modified conventional agronomic machines, such as forage harvesters. These typically require around one hour to harvest and chip each hectare. The wet (50 % moisture) chips produced would very quickly deteriorate by microbial activity if they were simply heaped on hard standing, so they must be ventilated for storage.

Harvesting can be done at any time between leaf fall and bud-burst. In the UK this is usually between mid-November and mid-March, but can vary considerably both with season and species.

### **Sources**

- (1) [www.fao.org/regional/europe/escorena/b46/cover.pdf](http://www.fao.org/regional/europe/escorena/b46/cover.pdf) "RENEWABLE ENERGY- Potential energy crops for Europe and the Mediterranean region" Regional Office For Europe (REU).
- (2) Federal Agricultural Research Centre (FAL) Braunschweig, Germany.
- (3) Reinhardt, G., Zemanek, G. (2000): Ökobilanz Bioenergieträger, Erich Schmidt Verlag, Berlin, 2000.
- (4) Statistisches Jahrbuch über Ernährung, Landwirtschaft und Forsten 2001, Münster 2001.
- (5) Kaltschmitt, M., Hartmann, H. (2001): Energie aus Biomasse, Springer Verlag, Berlin, ..., 2001.
- (6) Reinhardt, G., Kaltschmitt, M. (1997): Nachwachsende Energieträger, Vieweg Verlag, Braunschweig / Wiesbaden, 1997.
- (7) [www.dainet.de/fnr/veroff/schnellwbaeume.pdf](http://www.dainet.de/fnr/veroff/schnellwbaeume.pdf).



<b>Module</b>	<b>P17</b>	<b>Grass cultivation (i.e. perennial ryegrass)</b>
<b>General description of the process, regional aspects, outlook</b>		

Perennial ryegrass (*Lolium perenne*) is a perennial plant whose greatest importance has been its utilisation as feed. The plant produces above ground stolons and grows to heights ranging from 30-70 cm or more. The growth of the mature crop varies between semi-erect and semi-prostrate. The leaf blades are small, with a width of only up to 5 mm. They are dark green in colour with a grooved top-side and a keeled, smooth and glossy underside. The inflorescence is a two-rowed ear that grows to a length of up to 20 cm. The plant flowers in May or June. Perennial ryegrass is commonly infected with the *Endophytic fungus, Acremonium lolii*. In this mutualistic relationship the fungus produces alkaloids that have been shown to lead to disorders in livestock, but confer insect resistance to the plant.

Grass may be used as fodder or for energy purpose. Grass silage can be processed to fuel or biogas in adapted biogas plants.

### **Agronomic requirements**

Temperate zones, subtropics and tropical highlands are regions with the most suitable climate for perennial ryegrass cultivation. The plant is not tolerant to drought, wet soil and salt. Most important for the crop's growth are firm, nutrient rich soil and a mild, humid climate. Depending on the variety it is also sensitive to snow cover and late frosts, though it has been shown to have good regenerative capabilities

### **Crop management**

Perennial ryegrass is propagated using seed. The crop is sown at the end of summer/beginning of fall using about 25-35 kg ha<sup>-1</sup> seed. Perennial ryegrass has a high demand for fertilisers, especially nitrogen. In Germany ryegrass field tests at several locations have used fertiliser rates that varied as follows:

nitrogen 280-380 kg ha<sup>-1</sup> (300)

phosphorus 90- 160 kg ha<sup>-1</sup> (110)

potassium 175-465 kg ha<sup>-1</sup> (250)

magnesium 49 kg ha<sup>-1</sup>

Of these values a large percent of fertiliser is supplied in the form of liquid manure. The fertiliser rates vary with soil composition.

Among the diseases most damaging to annual ryegrass crops are mold (*Fusarium nivale*) and rusts (*Puccinia spp.*).

Field tests where perennial ryegrass was harvested once a year at the onset of flowering provided yields averaging between 7.4 and 12.7 t ha<sup>-1</sup> dry matter. The plants dry matter content averaged around 32-33 %.

### **Crop rotation**

Little research has been performed to determine an appropriate crop rotation for perennial ryegrass. In addition, it is a perennial plant with several years of significant yields once the crop has reached maturity.

**Regional aspects**

Yields differ according to climatic conditions.

**Outlook**

Research is underway testing harvests varying from 1-5 times per year.

**Provision chains**

The perennial ryegrass crop is harvested by mowing. With the crop being harvested 5 times per year, the first harvest takes place when the crop is approximately 40-60 cm high. This corresponds to harvests taking place about every 3-4 weeks from around the end of May through until the middle of October. The crop should be carefully harvested and quickly dried when it is to be used as fodder. When it is grown simply for biomass production the feed quality of the harvest is not important. It is important that the harvested material be sufficiently dried for storage and/or economic utilisation as a biofuel. When used as silage the crop is processed immediately.

**Sources**

- (1) Kusterer, B., Wurth, W. (1994): Ergebnisse der Landessortenversuche mit ausdauernden Gräsern 1994; Information für die Pflanzenproduktion. Heft 3/1 995. Landesanstalt für Pflanzenbau Forchheim.
- (2) Rehm, S., Espig, G. (1992): The Cultivated Plants of the Tropics and Subtropics; Verlag Joseph Margraf, Priesse GmbH, 1992, Berlin.
- (3) Federal Agricultural Research Centre (FAL) Braunschweig, Germany.
- (4) Reinhardt, G., Zemanek, G. (2000): Ökobilanz Bioenergieträger, Erich Schmidt Verlag, Berlin, 2000.
- (5) Statistisches Jahrbuch über Ernährung, Landwirtschaft und Forsten 2001, Münster 2001.
- (6) Kaltschmitt, M., Hartmann, H. (2001): Energie aus Biomasse, Springer Verlag, Berlin,..., 2001.
- (7) Reinhardt, G., Kaltschmitt, M. (1997): Nachwachsende Energieträger, Vieweg Verlag, Braunschweig / Wiesbaden, 1997.



Module	R1	Straw from cereals cultivation (i.e. wheat)
<b>General description of the process, regional aspects, outlook</b>		

Winter wheat is a member of the *Gramineae* family and has been described in module P6. After harvesting the wheat, the straw is a residue from the agricultural production of grains. In principle the whole straw can be used as an energy source, but the agricultural praxis has shown that a certain part of the straw must be used to close the nutrient cycle of the soil. A further part of the straw is used for animal production as bedding material or fodder. After this material use it will be partly worked into the nutrient cycle of the soil as a form of manure. The rest of the straw can be taken out of the nutrient cycle of the soil and thus be used as an energy source. Straw can be used for energy purpose in combustion systems or be processed to fuel in adapted fermentation applications.

#### **Agronomic requirements**

Winter wheat is the most ecologically demanding plant under the cereals. It prefers deep, nutrient rich, soils, with a good water supply. Winter wheat can survive temperatures of about -20 °C. In the 3-5 leaf stage the winter wheat is very frost sensitive (see P6).

#### **Crop management**

The straw is only a residue from winter wheat cultivation, so it will be not regarded in the crop management. About 5 t ha<sup>-1</sup> are harvested.

#### **Crop rotation**

Winter wheat should be planted in crop rotation, but not after cereal crops. Seeding it into stubble from broad-leaved crops, such as canola, mustard and peas, will reduce the risk of insect, disease and weed problems for all crops in the rotation (see P6).

#### **Regional aspects**

Straw is also used for other purposes, e.g. horse rearing or strawberry plantations. Its potential is not good in regions where such competing purposes have a considerable importance.

#### **Outlook**

It is assumed that the development of agriculture will not increase yields in the EU 15 and new EU countries.

<b>Provision chains</b>
-------------------------

By the time the grain is harvested the plant has died and the remaining straw contains very little moisture. Several handling methods are possible: pelleting, briquetting, baling and wafering. Most commonly baling is used. Transportation is mainly realised with tractor-drawn tailors. Bales are either used directly (combustion in adapted plants) or indirectly after further processing steps. Bales can be stored roofed and well ventilated over a long period of time.

## Sources

- (1) Thrän, D., Kaltschmitt, M. (2001): Stroh als biogener Festbrennstoff in Europa. IE, Leipzig, 2001.
- (2) [mars.aris.sai.jrc.it/documents/stats/bulletin/mars-05-1997.pdf](http://mars.aris.sai.jrc.it/documents/stats/bulletin/mars-05-1997.pdf).
- (3) Reinhardt, G., Zemanek, G. (2000): Ökobilanz Bioenergieträger, Erich Schmidt Verlag, Berlin, 2000.
- (4) Statistisches Jahrbuch über Ernährung, Landwirtschaft und Forsten 2001, Münster 2001.
- (5) Kaltschmitt, M., Hartmann, H. (2001): Energie aus Biomasse, Springer Verlag, Berlin,..., 2001.
- (6) Reinhardt, G., Kaltschmitt, M. (1997): Nachwachsende Energieträger, Vieweg Verlag, Braunschweig / Wiesbaden, 1997.



Module	R2	Collecting of animal excrements
<b>General description of the process, regional aspects, outlook</b>		

Excrements from the keeping of domestic cattle, pigs and poultry are accumulate faeces from agriculture. The basic materials for this biomass fraction-group are dejection that accrued mostly as solids, whereas the urine is accrued as liquid. As a function of animal husbandry either both basic materials as well as the interspersing material (slurry) or excrement and urine without other additives (manure) accrue. The amount and consistence of the excrements range significantly depending on feeding and other parameters. All animals produce excrements, but for biomass potential only the excrements from cows, pigs and poultry are utilisable. This is founded in the different kinds of the animal husbandry. Animals like sheep and goats are mainly outside during the year, so there is no possibility for collecting their excrements. Excrements can be used in fermentation processes to produce biogas.

### **Pig slurry**

Up to six varieties of different types of animal housing are commonly in use, resulting in large variations of total solids (2-10 %) and organic dry matter content in manure. The excrements from pigs, particularly in units with more than 1000 animals, are commonly collected as a liquid manure. In most cases, pigs are kept in feedlots with open floors, where the excrements are collected through slots with high amounts of liquid.

### **Cow slurry**

Cow slurry is typically collected from feedlots by a scraper system. Straw is often added in the feedlots resulting in slight variations of total solids. Commonly little water is added for cleaning and rinsing of the cattle walkway, hence dilution with water is minimal. As for pig slurry, cow slurry also exhibits large variations in total solids contents, depending on the animal housing system. Depending on the location and operational tradition cows often spend long periods of time grazing on pastures.

### **Poultry manure**

Chickens are usually kept in large-scale units holding up to several hundred thousand animals. Poultry manure is characteristically high in TS contents (~20 %) and  $\text{NH}_4^+$ -N concentrations (the  $\text{NH}_4^+$ -N concentration of animal slurries is generally rather high). In most cases, water dissolved ammonia is excreted. Since chickens excrete little liquid, ammonia may be found in crystalline form in the excrements. The resulting high ammonia content can lead to inhibitory effects during digestion, causing high  $\text{NH}_3$  emissions during manure storage in the feedlots.

Excrements from animal housing are often used as fertiliser and so the nutrients can be repatriated on agricultural areas. The digestion of the excrements, before it will be repatriated to agricultural areas, poses no problem for closing the nutrient cycle of the solid.

### **Regional aspects**

There are no relevant specifications concerning the collecting of animal excrements in barns.

## Outlook

The development depends on agricultural policy in the EU. If organic farming increases, the animals will spend less time inside. Outside, a systematic collection of the manure is not possible - so the availability of the total potential will drop. Another reason for a decreasing potential could be a decrease of meat production caused by a trend to a healthier diet or caused by rising meat imports from the world market.

## Provision chains

The excrements are accumulated essentially in agriculture. They are most often used as fertilisers in crop production. Using excrements in fermentation processes first, to produce biogas, often reduces odours and atmospheric relevant emissions and improves the quality of the fertilisation impact of the utilised excrements.

## Sources

- (1) Statistisches Jahrbuch über Ernährung, Landwirtschaft und Forsten, Münster 2001.
- (2) [http://www.nsi.bg/Stat\\_e/Bulgaria-World/Agr2-e.htm](http://www.nsi.bg/Stat_e/Bulgaria-World/Agr2-e.htm).
- (3) <http://www.stats.uwo.ca/computing/datasets/datasets/CLEVELAN/EGDATA/LIVESTOC>.
- (4) "Energie aus Biomasse" Kaltschmitt/Hartmann Springer Verlag 2001.
- (5) <http://www.ad-nett.org/assets/images/Feednw1.pdf>.



<b>Module</b>	<b>R3</b>	<b>Collecting of vegetable residues from agriculture</b>
<b>General description of the process, regional aspects, outlook</b>		

During agricultural plant production relatively moist harvest residues accumulate. For example, only a part of the grown biomass from producing of vegetables such as green peas and bush beans are utilisable for human food. Also when harvesting root crops (e.g. sugar beets, potatoes), residues and by-products accrue. During the harvesting of sugar beets a significant leaf mass is accrued (40-50 t ha<sup>-1</sup> a<sup>-1</sup>). In practice the leaf mass is used for fodder. Considering the cultivation of potatoes, the grown biomass useable as an energy source is small. As a result of the high water content of the leaf mass, the use of the relative moist harvest residues as solid fuel is not possible. The use of vegetable residues is only conceivable for the production of biogas.

### Regional aspects

No relevant specifications are known.

### Outlook

The amount of residues depends mainly on the prevailing cultures. A forecast of agricultural policy is not possible, the crops to be cultivated can be influenced countless factors.

### Provision chains

The residues are accumulated essentially in the agriculture. They are most often used as fodder. Parts of them could be used in fermentation processes as well, to produce biogas.

### Sources

- (1) "Landwirtschaftliche Reststoffe" Ruhrgas Studie - ECOfys.
- (2) Statistisches Jahrbuch über Ernährung, Landwirtschaft und Forsten 2001, Landwirtschaftsverlag Münster-Hiltrup.
- (3) <http://www.brh-gov-pl.or.at/monograf/plland02.htm>.
- (4) <http://www.new-agri.co.uk/00-3/countrysp.html>.
- (5) "Abfallwirtschaft" Bilitewski/Härdtle/Marek Springer Verlag 1990.
- (6) "Energie aus Biomasse" Kaltschmitt/Hartmann Springer Verlag 2001.



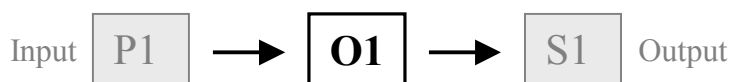

Module	O1	Vegetable oil from rape seed
<b>General description of the process, regional aspects, outlook</b>		

A vegetable oil or vegoil is an oil extracted from oilseeds or another plant source.

Like all fats, vegetable oils are esters of glycerin and a varying blend of fatty acids, and are insoluble in water but soluble in organic solvents.

The vegetable oil fuel can be used directly in suitable engines. Another possibility is to utilise the vegetable oil fuel in diesel engines after a transesterification (see module S1). The majority of European rape seed oil production is used to produce biodiesel.

**Extraction.** Vegetable oil fuels are gained from oil seeds either in industrial sized oil mills (up to 4,000 t d<sup>-1</sup>) or in small mills (0.5 to 25 t d<sup>-1</sup>). Different techniques are used, due to size or source and different qualities of oil are produced (in the refinery process). Basically, two different processes of extraction are utilised:

- The fluid oil phase can be separated from the solid phase (the so-called press substrate) by simple **mechanical pressing**. This is done by expeller presses.
- An additional or alternative method is the **extraction**. The oily crop is removed from the oil substrate by a solvent. This process produces higher yields.

**Industrial sized oil mills.** Mills of this size are mostly located next to water transports routes because up to 4,000 t of seed are worked off per day. Next to navigation vessels, trains and trucks are used as transportation devices. The process utilised in these kinds of oil mills does not differ from processes used for alimentation purposes, only the quality of the final product may. The rape seed oil extraction process can be divided into the following steps: pre-treatment, pressing, extraction and purification of the separated components.

**Pre-treatment.** Depending on the quality of the seed an additional cleaning step may be necessary. If required the seed is peeled afterwards. Usually, different sets of rolls are used to crack the outer shell of the seed but do not harm the body. Separating the shells from the seed before pressing improves the quality of the press substrate and oil. This step is followed by crushing the seed to increase the surface for oil discharge. Finally, the grist is conditioned concerning moisture content and temperature.

**Pressing.** The pre-treated seeds are pressed out in a continuous mechanical process. Usually, screw presses are used. Despite their size, screw presses do not differ in construction between small and industrial sized oil mills. Figure 1 shows one example of this kind of machine. The functional principle is a pressing screw rotating in a cylinder. The space between screw and cylinder decreases in direction of the substrate flow. Two products emerge from this process: raw oil and press substrate. The oil includes small particles of the seed that have to be filtered out afterwards. The oil is combined with the oil gained from the extraction step and is finally purified. The press substrate and filtered particles are combined and feed the extraction step of the process. The press substrate still includes 15-20 % of oil content.

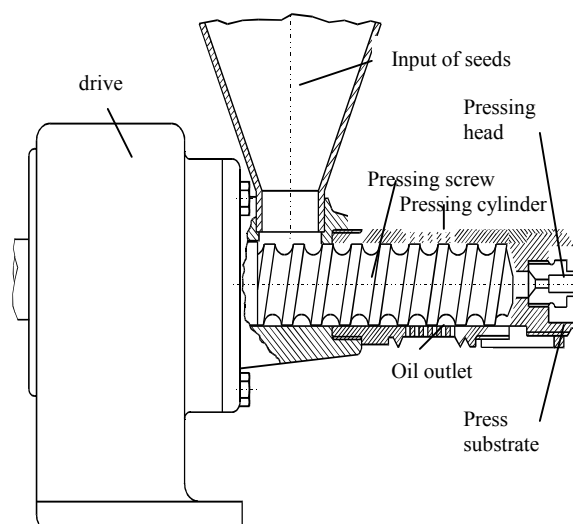

**Figure 1:** Screw press

**Extraction.** The remaining oil in the press substrate is extracted with aid of a solvent. Hexane is usually used, since it best serves all physical and practical demands, concerning a solvent. The so-called miscella (the oil-solvent-mixture, 20-30 % oil, 70-80 % solvent) remains as fluid phase, the extraction grist as solid substrate. The miscella and the solid substrate have to be purified by distillation afterwards. The solvent is utilised in closed circle in the process. The advantage of the extraction is that in comparison to the pressing, significantly more oil can be gained from the same oil crop.

For very oily crops like rape seed, a combination of pressing and an (downstream) extraction is often used, especially in industrial sized oil mills.

The process in **small oil mills** usually includes pre-treatment, pressing and purification of the products. A secondary extraction with a solvent to increase the yield is mostly not used. Vegetable oil, respectively its raffinate, is different in **essential characteristics** from diesel fuel (e.g. its high viscosity) and even more from gasoline-fuel.

### Regional aspects

The technology has no relevant regional specifications.

### Outlook

For this well approved technology, no significant technological changes are assumed.

Sources
---------

- |  |
|--|
| <ol style="list-style-type: none"> <li>(1) Kraus, K. et al. (1999): Aktuelle Bewertung des Einsatzes von Rapsöl/RME im Vergleich zu Dieselkraftstoff, Umweltbundesamt (Hrsg.).</li> <li>(2) Kaltschmitt, M., Reinhardt, G. (1997): Nachwachsende Energieträger - Grundlagen, Verfahren, ökologische Bilanzierung.</li> <li>(3) Bundesministerium für Ernährung, Landwirtschaft und Forsten (2000): Agenda 2000, Pflanzlicher Bereich, Agrarumweltmaßnahmen.</li> <li>(4) Scharner, K. (1995): Energy balance, ecological impact and economics of vegetable oil methylester production in Europe as substitute for fossil diesel. EU-Studie ALTENER 4.1030/E/94-002-1.</li> <li>(5) <a href="http://www.stmwvt.bayern.de/Themen/Erneuerbare_Energien/">www.stmwvt.bayern.de/Themen/Erneuerbare_Energien/</a>.</li> <li>(6) <a href="http://www.biodiesel.de">www.biodiesel.de</a>.</li> </ol> |
|--|

- (7) <http://bioenergy.ornl.gov/doiofd/index.html>.
- (8) <http://pubs.acs.org/journals/esthag-a/links/energy.html#biofuels>.
- (9) <http://www.eurec.be/htm/expertise/biomass.htm>.
- (10) <http://www.afdc.nrel.gov/altfuel/biodiesel.html>.
- (11) <http://www.dlr.de/TT/system/publications/epolitik>.
- (12) <http://www.ufop.de/home.html>.
- (13) <http://www.umweltbundesamt.de/uba-info-presse-e/presse-informationen-e/p0100e.htm>.
- (14) <http://www.agrarberatung-hessen.de/markt/analysen/0103102001032101.htm>.

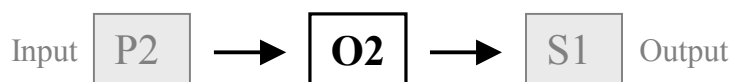

Module	O2	Vegetable oil from olives
<b>General description of the process, regional aspects, outlook</b>		

Olives are pressed in the regions where they are harvested. Experiences with the procedure has existed for a long time. The procurement price of olives is relatively high; hence, fuel production from olives is not economical. However, olive oil could achieve a considerable market share in the nourishment industry in spite of its relative prices. Consequently, the extraction of olive oil is primarily relevant for the nourishment industry. An industrial olive oil fuel production does not exist at the moment.

Valuable data for large scale applications are not available. For domestic use, the price of olive oil is far higher than the price of sunflower oil.

The process in **small oil mills** usually includes pre-treatment, pressing and purification of the products. A secondary extraction with a solvent to increase the yield is mostly not used.

**Pre-treatment.** Depending on the quality of the fruit an additional cleaning step may be necessary. Stems, twigs and leaves are removed and the olives may or may not be cleaned with water to remove pesticides, dirt, etc. Stones (rocks) and sand will quickly wear out a centrifugal decanter or oil separator, reducing its life span from 25 to as little as 5 years.

**Grinding the olives to paste.** The following step is crushing the olives (including the olive pits) to increase the surface for oil discharge. Finally, the grist is conditioned concerning moisture content and temperature.

**Mixing to increase olive oil yield.** Mixing or malaxation for 20-40 minutes allows small oil droplets to combine into bigger ones which can be removed in the next step. It is a necessary step. The paste is often heated to 28 °C during this process. The most common mixer is a horizontal trough with spiral mixing blades.

**Separating the oil and water from the fruit (pomace).** Different types of separators are used. Either hydraulic presses, that squeeze the paste which has been applied to stacks of filter like discs, screw presses or centrifugal decanters are utilised.

**Separating the oil from the water.** Centrifugal separators are used in this step or oil and water are put into tanks where they separate by gravity. Finally, different **processing steps** to condition the oil may follow (this applies mainly, when using the oil for nourishment). Refining the oil with steam or alkali to reduce acidity and improve the flavour of the oil. Also bleaching or deodorisation to reduce chlorophyll or odours may be utilised.

**Storage.** Olive oil can be stored in containers as mundane as plastic or as indestructible as stainless steel. Oil deteriorates through the action of lipase and other enzymes in the oil and the action of oxygen. Oxidation or rancidity speeds up with light and heat exposure.

Vegetable oil respectively its raffinate is different in **essential characteristics** from diesel fuel (e.g. its high viscosity) and even more from gasoline-fuel.

### **Regional aspects**

The technology has no relevant regional specifications.

### **Outlook**

For this well approved technology, no significant technological changes are assumed.

<b>Sources</b>
----------------

- (1) Kaltschmitt, M., Reinhardt, G. (1997): Nachwachsende Energieträger - Grundlagen, Verfahren, ökologische Bilanzierung.
- (2) <http://bioenergy.ornl.gov/doeofd/index.html>.
- (3) <http://pubs.acs.org/journals/esthag-a/links/energy.html#biofuels>.
- (4) <http://www.eurec.be/htm/expertise/biomass.htm>.
- (5) <http://www.dlr.de/TT/system/publications/epolitik>.
- (6) <http://www.ufop.de/home.html>.

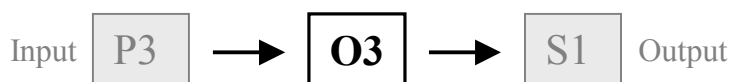

Module	O3	Vegetable oil from soybeans
<b>General description of the process, regional aspects, outlook</b>		

The oil is obtained from the soybean seeds most usually by solvent extraction. The oil consists of 3-11 % linoleic acid. Vegetable oil of soybeans for example has a share of 20 % of the total German oil plants production.

The utilised process of extraction of the vegetable oil from soybeans results from the stability of the soybean in comparison to the rape seed or sunflowers. The extraction grist is processed in the forage and nourishment industry at world prices. The vegetable oil fuel can directly be used in suitable engines or - indirectly after a transesterification process (see module S1) - in conventional diesel engines, too.

The soybean oil extraction process can be divided into the following steps: pre-treatment, extraction and purification of the separated components.

**Pre-treatment.** Depending on the quality of the seed an additional cleaning step may be necessary. This step is followed by crushing the seed to increase the surface for oil discharge. Finally, the grist is conditioned concerning moisture content and temperature.

**Extraction.** The oil in the grist is extracted with aid of a solvent. Hexane is usually used, since it best serves all physical and practical demands, concerning a solvent. The so-called miscella (the oil-solvent-mixture, 20-30 % oil, 70-80 % solvent) remains as a fluid, while the extraction grist remains as a solid substrate. The miscella and the solid substrate have to be purified by **distillation** afterwards. The solvent is utilised in a closed circle in the process.

The advantage of the extraction by solvent is that in comparison to pressing, significantly more oil can be gained from the same oil crop.

For very oily crops like rape seed, a combination of pressing and a (downstream) extraction is often used, especially in industrial size oil mills (see module O1).

Vegetable oil, respectively its raffinate, is different in **essential characteristics** from diesel fuel (e.g. its high viscosity) and even more from gasoline-fuel.

### Regional aspects

The technology has no relevant regional specifications.

### Outlook

For this well approved technology, no significant technological changes are assumed.

### Sources

- (1) Kaltschmitt, M., Reinhardt, G. (1997): *Nachwachsende Energieträger - Grundlagen, Verfahren, ökologische Bilanzierung.*
- (2) Bundesministerium für Ernährung, Landwirtschaft und Forsten (2000): *Agenda 2000, Pflanzlicher Bereich, Agrarumweltmaßnahmen.*

- (3) Scharner, K. (1995): Energy balance, ecological impact and economics of vegetable oil methylester production in Europe as substitute for fossil diesel. ALTENER-study 4.1030/E/94-002-1.
- (4) <http://bioenergy.ornl.gov/doeofd/index.html>.
- (5) <http://pubs.acs.org/journals/esthag-a/links/energy.html#biofuels>.
- (6) <http://www.eurec.be/htm/expertise/biomass.htm>.
- (7) <http://www.afdc.nrel.gov/altfuel/biodiesel.html>.
- (8) <http://www.dlr.de/TT/system/publications/epolitik>.
- (9) <http://www.ufop.de/home.html>.
- (10) Schmerz, H.; Senser, F. (Deutsche Forschungsanstalt für Lebensmittelchemie (Hrsg.): Food Composition and Nutrition Tables, Stuttgart, 1994.

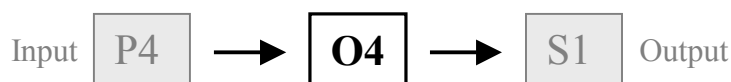

<b>Module</b>	<b>O4</b>	<b>Vegetable oil from sunflower seeds</b>
<b>General description of the process, regional aspects, outlook</b>		

In general, the processing of "soft oil plants" in the oil mill (in refinery processes) to vegetable oil fuels is independent from the deployed oil plant in the converting process. The extraction of **vegetable oil** from sunflowers (with a production share of 5 % in German oil plant production) results from pressing and/or extraction of the oil contained in organic substances. The co-products press substrate and extraction grist are processed in the forage and nourishment industry at world prices. The vegetable oil fuel can directly be used in suitable engines or - indirectly after a transesterification process (see module S1) - in conventional diesel engines, too.

- The fluid oil phase can be separated from the solid phase (the so-called press substrate) by simple **mechanical pressing**.
- An additional or alternative method is the **extraction**. The oily crop is withdrawn from the oil substrate by a solvent. The so-called miscella (an oil-solvent-mixture) remains as fluid phase, the extraction grist as solid substrate. The miscella then has to be purified by distillation afterwards. The advantage of the extraction by solvent is that in comparison to the sole pressing, significantly more oil can be gained from the same oil crop. Therefore, in the case of very oily crops like sunflower seed, a combination of pressing and an (downstream) extraction is often realised.

Vegetable oil, respectively its raffinate, is different in **essential characteristics** from diesel fuel (e.g. its high viscosity) and even more from gasoline-fuel.

### Regional aspects

The technology has no relevant regional specifications.

### Outlook

For this well approved technology, no significant technological changes are assumed.

### Sources

- (1) Kaltschmitt, M., Reinhardt, G. (1997): *Nachwachsende Energieträger - Grundlagen, Verfahren, ökologische Bilanzierung*.
- (2) Bundesministerium für Ernährung, Landwirtschaft und Forsten (2000): *Agenda 2000, Pflanzlicher Bereich, Agrarumweltmaßnahmen*.
- (3) Scharner, K. (1995): *Energy balance, ecological impact and economics of vegetable oil methylester production in Europe as substitute for fossil diesel*. ALTENER-study 4.1030/E/94-002-1.
- (4) <http://bioenergy.ornl.gov/doeofd/index.html>.
- (5) <http://pubs.acs.org/journals/esthag-a/links/energy.html#biofuels>.
- (6) <http://www.eurec.be/htm/expertise/biomass.htm>.
- (7) <http://www.afdc.nrel.gov/altfuel/biodiesel.html>.



- (8) <http://www.dlr.de/TT/system/publications/epolitik>.
- (9) <http://www.ufop.de/home.html>.
- (10) ZMP (Hrsg.): Ölsaaten Spezialinfo, 2002-04-30 ([http://www.zmp.de/produkte/leseproben/oelsaaten\\_Spez.pdf](http://www.zmp.de/produkte/leseproben/oelsaaten_Spez.pdf)).
- (11) Schmerz, H., Senser, F. (Deutsche Forschungsanstalt für Lebensmittelchemie (Hrsg.): Food Composition and Nutrition Tables, Stuttgart, 1994.



Module	T1	Methanol from woody biomass
<b>General description of the process, regional aspects, outlook</b>		

Methanol, also known as methyl alcohol or wood alcohol, is a chemical compound with the chemical formula CH<sub>3</sub>OH. It is the simplest alcohol, and is a light, volatile, colourless, flammable, poisonous liquid. Methanol is used as a solvent and as antifreeze in pipelines. The largest use of methanol by far, however, is in making other chemicals. About 40 % of methanol is converted to formaldehyde, and further on into products as diverse as plastics, plywood, paints, explosives, and permanent press textiles. Methanol has been considered as a fuel, mainly in combination with gasoline. Its main advantage is that it can be easily manufactured from methane (the chief constituent of natural gas) as well as by pyrolysis of many organic materials (biomass).

**Production from fossil sources.** Today, synthesis gas is most commonly produced from the methane component in natural gas rather than from coal. At moderate pressures of 1-2 MPa (10-20 atm) and high temperatures (around 850 °C), methane reacts with steam on a nickel catalyst to produce syngas according to the chemical equation:

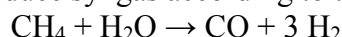

This reaction is commonly called steam-methane reforming. The carbon monoxide and hydrogen then react on a second catalyst to produce methanol:

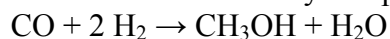

Today, the most widely used catalyst is a mixture of copper, zinc oxide, and alumina. At 5-10 MPa (50-100 atm) and 250 °C, it catalyses the production of methanol.

**Production from organic material.** The gasification is an important intermediate step in the production of methanol. The following processing steps are necessary according to the state of the art of the fuel technology:

- wood conditioning by comminution and drying
- The production of the synthesis gas by gasification, conditioning and purification; the composition of the produced synthesis gas often does not have the necessary requirements of the methanol-synthesis. Therefore, a conversion process follows in order to match the respective synthesis gas characterisations.
- The actual methanol-synthesis of the conditioned synthesis gas is already state of the art. After the synthesis follows a process of distillation for the raw methanol, in which by-products are secluded and methanol with the required purity is produced.

In the following, each single process step is evaluated of its efficiency. Thereby, it is accessed by the know-how of the classic fuel and energy technology.

- **Comminution:**

Shedder plants are applied for the comminution of wood. Unfortunately, the delivered grist structure is unfavourable to use for a carburettor. An improved result of barks (better grain sizes) could be available with a higher operating expense in the future.

The process of the comminution requires bunker, interim bunker, possibly cycle circuits with screens and comminution plants. The great amount of required electric energy is estimated of

approx.  $50 \text{ kWh t}^{-1}$ . Therefore, an efficiency of  $\eta_z = 98.0 \%$  is the outcome of this process step. Whereas the electricity generation is specified with  $\eta_{el} = 70 \%$ .

- **Drying**

Heat energy in the form of steam, flue gas, hot air and the like must be expended for drying. The drying expense is about  $0.9\text{-}1.0 \text{ kWh kg}^{-1}$  vaporised water. One share of the heat can be regained by modern plants via the use of the exhaust vapour heat. Further expenses are necessary in the form of electric energy. Hence, a partial efficiency of  $\eta_T = 94.5 \%$  is the result of excluding the exhaust vapour heat recovery.

- **Production of the synthesis gas**

The considerable know-how of coal upgrading can be used here. Poor-gas generation plants with condensation and purification had a thermal efficiency of  $60 \%$ . The optimised proceeding of the solid state pressure gasification with oxygen resulted in  $65 \%$  including the valuation of all produced products (gas, tar, oil, phenol) and by very good gas purification (Rectisol-proceeding). If assumed that a partial converting is required and this process uses great amounts of the rejected heat (efficiency  $95 \%$ ) then the efficiency of  $\eta_{SGAS} = 62 \%$  is for the provision of the synthesis gas.

- **Methanol synthesis**

If the yield and consumption performance figures as described before are the basis, the thermal efficiency results in  $\eta_{Syn} = 57.1 \%$  only for the synthesis process. Admittedly, further  $28 \%$  are available as secondary energy sources (steam / residue gas). Thus, an efficiency of  $\eta_{Syn} = 70 \%$  results from the synthesis, if it can be provided that  $50 \%$  of the secondary energy sources are used.

- **The total efficiency of the proceeding chain**

The multiplication of the partial efficiencies causes the following total efficiency of the proceeding chain biomass (wood) - liquid energy source methanol:

$$\eta_{Ges \text{ B-Meth}} = \eta_z \cdot \eta_T \cdot \eta_{SGAS} \cdot \eta_{Meth.} = 0.40$$

## Regional aspects

The technology has no relevant regional specifications.

## Outlook

Methanol-synthesis plants have been built serially for a long time, but they were based on fossil fuels, such as coal or natural gas. Because of this, some technological descriptions of older sources are still valid. The development of biomass-based plants will lead to smaller plants for making the technology available in a more decentralised grid of transformation plants.

<b>Sources</b>
----------------

- (1) Krüger, R., Voß, A.: Systemanalytischer Vergleich innovativer Kraftstoffe und Antriebssysteme. In: Innovative Fahrzeugantriebe, Tagung Okt. 2000 in Dresden, VDI-Berichte 1565, VDI-Verlag, Düsseldorf, 2000.
- (2) Eckhardt / Ludwig: Freiburger Lehrbriefe Organisch-chemische Technologie, Lehrbuch 4, 1961.
- (3) Ullmanns Enzyklopädie der technischen Chemie, vol. 12.
- (4) Choren Industries (Hrsg.): Erneuerbare Kraftstoffe, Freiberg, 2001.



Module	T2	Pyrolysis oil from biomass
<b>General description of the process, regional aspects, outlook</b>		

Pyrolysis is a process for the reduction of complex organic materials (usually waste products of various sorts, often known as biomass) into light crude oil. Under the influence of pressure and heat, long chain polymers of hydrogen, oxygen, and carbon decompose into short-chain petroleum hydrocarbons.

**Process.** The feedstock material is first ground into small chunks, and mixed with water if it is especially dry. It is then fed into a reaction chamber where it is heated to around 250 °C and subjected to a pressure of 4 MPa for approximately 15 minutes, after which the pressure is rapidly released to boil off most of the water. The result is a mix of crude hydrocarbons and solid minerals, which are separated out. The hydrocarbons are sent to a second-stage reactor where they are heated to 500 °C, further breaking down the long chains, and the resulting petroleum is then distilled in a manner similar to conventional oil refining.

**Parameters.** The process as described forms gaseous, liquid and solid components. Their shares and composition can be influenced by process parameters of the pyrolysis and especially by the heating-up-rate. The resulting liquid components, e.g. by the flash-pyrolysis, are a mixture of different organic blends. Water and charcoal can be dissolved in it. This mixture is also called pyrolysis oil and generally cannot be stored because of the oxygen content. Therefore, the pyrolysis oil must be prepared for the use as fuel as necessary. Furthermore, it has to be matched to the common features of fossil fuels.

The volumetric consumption of pyrolysis oils is twice as high as that of diesel because the gross calorific value of the pyrolysis oil is only half of the one of diesel fuel.

The highest possible oil yield of the pyrolysis technology (the reactor water inclusive) is approximately 75 %. The average value is 56 % referring to the dry biomass. The optimal temperature range is about 450-500 °C.

Four chemical product groups emerge from the pyrolysis decomposition. Their shares - in dependency of the selected requirements of the pyrolysis - can vary substantially. The pyrolysis decomposition of the organic mass starts at nearly 220 °C with the formation of acetic acid (CH<sub>3</sub>COOH), water and gas. The gas is mainly composed of carbon dioxide (CO<sub>2</sub>), carbon monoxide (CO), methanol (CH<sub>3</sub>OH) and of charcoal together with shares of ash.

30 % of the woody substance is decomposed in the temperature range 320-340 °C. The maximums at about 400 °C - nearly 70 % loss of weight - mark the end of the removal of cellulose and hemicellulose and the zenith of the lignin decomposition.

In principle, the technical potential of pyrolysis oil-production is very good. Theoretically, the total solid biomass (in Germany: 1000-1200 PJ a<sup>-1</sup>), which is available for energy recovery, could be used for the pyrolysis oil production.

When a fuel should be provided for a fleet of vehicles, in which the fuel can be deployed without problems, a relatively high operating expense for processing is necessary. In the same way, a rise in costs would be inevitable. Therefore, the commercial implementation of this option in the energy sector is negligibly low at the moment. However, this technology comes into operation, especially in Canada.

## Regional aspects

The technology has no relevant regional specifications.

## Outlook

Especially in recent years, considerable research funds have been raised for the development of this technology in Europe. Nonetheless, such techniques still exist in a stadium of research and development. Up to now, it is even not possible to produce a storable fuel with defined characteristics without problems. Therefore, it is not possible to give detailed information on the future development of the described technology.

<b>Sources</b>
----------------

- (1) Kaltschmitt, M., Hartmann, H. (2001): Energie aus Biomasse - Grundlagen, Techniken und Verfahren.
- (2) Bridgewater, A.V., Bridge, S.A (1991): A review of biomass pyrolysis and pyrolysis technologies. In: Bridgewater, A.V. / Grassi, G. (Hrsg.) Biomass Pyrolysis Liquids Upgrading and Utilisation, Elsevier Appl. Sci., London 1991, S. 11-92.
- (3) Ormrod Diesels, Skelmersdale, Lancashire, UK 1999.
- (4) Andrews, R.G. et al (1997): Feasibility of firing an industrial gas turbine using a biomass derived fuel. In Bridgewater, A.V. / D.G.B. (Hrsg.): Developments in Thermo chemical Biomass Conversion, Blackie Academic, London 1997, S. 495-506.



Module	T3	Synfuel by therm. processing from biomass
<b>General description of the process, regional aspects, outlook</b>		

The first steps to synfuel production are the same as for methanol production (T1) because both reactions need a synthesis gas. The following processing steps are necessary according to the state of the art of the fuel technology:

- wood conditioning by comminution and drying
- The production of the synthesis gas by gasification, conditioning and purification; the composition of the produced synthesis gas often does not have the necessary requirements of the methanol-synthesis. Therefore, a conversion process follows in order to match the respective synthesis gas characterisations.

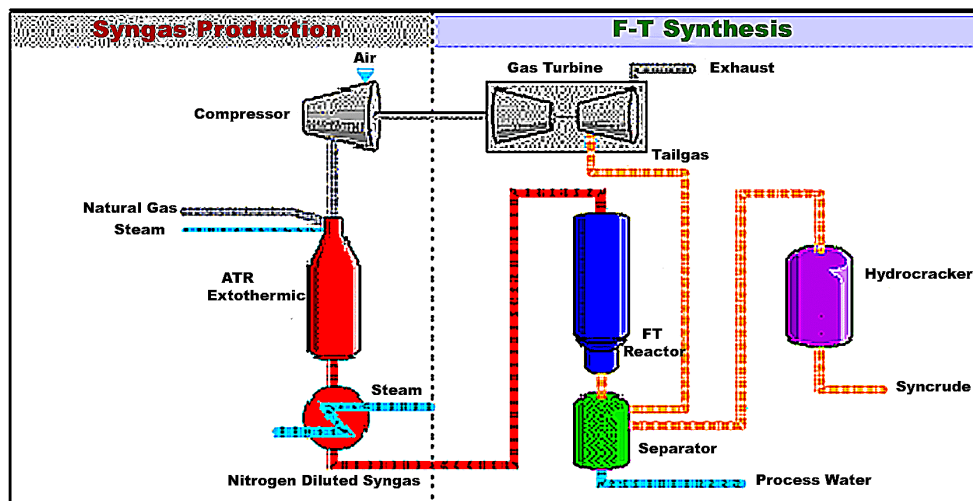

Figure 2: Process scheme of syngas production and F-T-synthesis

The Fischer-Tropsch synthesis uses carbon monoxide and hydrogen for producing alkanes. The temperatures during the reactions must be strictly controlled.

The synthesis has different options: Depending on the pressure, the temperature and on the used catalysts, different mixtures of hydrocarbons will result. For getting fuels substituting gasoline, the Kölbl-Rheinpreußen-procedure, a medium pressure variant, can produce the best mixture, containing up to 62 % of gasoline (i.e. fluent hydrocarbons from C<sub>5</sub> to C<sub>10</sub>).

After using a kiln where the gases have contact to the catalyst, different condensation steps lead to the isolation of different hydrocarbons. For these steps, the input of auxiliary energies may be 30 % higher than for a methanol synthesis. The resulting fuel is called synfuel and contains no aromates, no naphthene and no sulfur, but all those alkanes that are typical for gasoline.

### Regional aspects

The Fischer-Tropsch-synthesis has been developed in the 20<sup>th</sup> century; mainly for converting coal to vehicle fuels and other materials. The know-how had been developed in Germany and

in Great Britain (as well as outside Europe), but cheap mineral oil displaced the Fischer-Tropsch output during the last four decades of the 20<sup>th</sup> century. So a well established conversion technology has been rediscovered for the conversion of biomass, but there are no existing large scale industries so far in the member or accession countries of the EU.

### **Outlook**

New developments tend to the medium pressure synthesis rather than to normal pressure synthesis because the installations are more compact. New systems of catalysts can lead to more homogenous outputs and less by-products, so that the maximum share of vehicle fuels among the output products may rise. The third tendency is a trend towards a higher energy recycling rate (especially heat recovery) to improve the total energy efficiency of the process.

<b>Sources</b>
----------------

- (1) Eckhardt / Ludwig: Freiburger Lehrbriefe Organisch-chemische Technologie, Lehrbuch 4, 1961.
- (2) Ullmanns Enzyklopädie der technischen Chemie, vol. 12.
- (3) Personal communication of Dr. Berthold Gartner, 2002.



Module	F1	Ethanol from sugar beet
<b>General description of the process, regional aspects, outlook</b>		

Ethanol is a clear, uncoloured liquid. Ethanol from biomass is referred to as "bio-ethyl-alcohol". Ethanol is used in a wide variety of industrial processes or also used as antifreeze for its low melting point. Ethanol can be obtained from petroleum or natural gas, but is easily processed from sugar or starch in crops and other agricultural products. When ethanol is mixed into gasoline, the result is known as gasohol. Ethanol is produced in a process of fermentation and distillation.

- The **fermentation** describes the process of the transformation of glucose, which is contained in sugar beet, to ethanol and carbon dioxide via a yeast enzyme.
- Afterwards, the solvent is **distilled** and with it the ethanol is concentrated. 96 % ethanol and 4 % water is the max. achievable concentration, that can be reached via distillation. The remaining water can be detracted via chemical substances. A concentration level of 100 % can be accomplished.

Starchy and sugary plants can be used for the production of ethanol. In Europe these are mainly wheat and sugar beet at the moment. Figure 3 gives an overview of the conversion routes of the ethanol production.

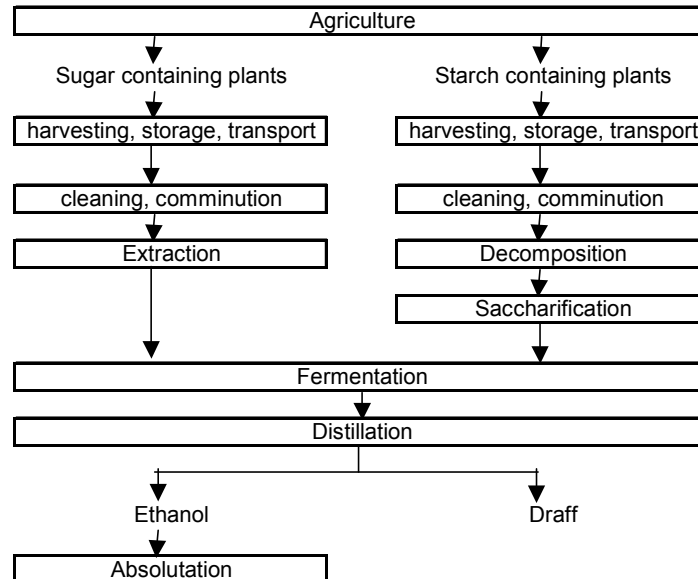

**Figure 3:** Ethanol conversion routes

Established procedures are used for ethanol production from sugar beet. The converting process is divided in different steps: washing, break-up and sugar extraction. In the sugar beet manufacture, the washing water is anaerobic and aerobically treated in existing refurbishment plants. Thereafter, it is directed to the on-site pre-flooder. A sugary solvent and beet chips are the end products of the extraction. The raw sap is fermented. Absolute alcohol is produced from the fermented sap by distillation.



Pure ethanol melts at  $-114\text{ }^{\circ}\text{C}$ , boils at  $78\text{ }^{\circ}\text{C}$  and has a density of  $0.79\text{ kg dm}^{-3}$  at  $20\text{ }^{\circ}\text{C}$ . The energy content is comparable with gasoline. The possible use of ethanol in combustion engines is similar to the use of conventional fuels.

If bio-ethanol production plants are restricted in source (e.g. sugar beet) they cannot be operated at full capacity during the whole year. In autumn, sugar beets are harvested and have to be processed by February the following year. Therefore, the planning of plants which are able to accept varied input substances is recommended to improve full use of the conversion plants capacity.

### Regional aspects

Within the EU, bio-ethanol is used only in France as a base for producing ethyl-tertiary-butyl-ether (ETBE). However, the market penetration is very low due to the absence of the exemption of the mineral-oil-tax.

In Germany, only a few plants have been in operation since last year.

### Outlook

In Europe, no fixed production targets exist besides the proposal for a directive on the promotion and the use of biofuels for transport (use of 5.75 % of biofuels in 2010).

In France, bio-ethanol production is expected to continue to grow. Officials assume that bio-ethanol could close the gap with fossil fuels at the macro-economic level within the next 10 years in France.

A working group at the Ministry of Agriculture of Latvia is developing a programme of biofuel production and use within 2000-2010. Today three ethanol factories with a total annual capacity of 11 million litres of ethanol operate in Latvia.

Bio-ethanol can be used without any operating problems or environmental risks and the refinery technology for production of bio-ethanol already exists in Europe. Increased use of biofuels at present can only be obtained if there is a high rate of tax relief and subsidised raw material production.

The Commission proposes that a market-share of two percent for liquid biofuels could still be considered as a pilot phase implementation. This level may well be reached in the short or medium term in some countries (in particular Austria, Germany, France and Italy).

<h3>Sources</h3>
------------------

- (1) Kaltschmitt, M., Reinhardt, G. (1997): *Nachwachsende Energieträger - Grundlagen, Verfahren, ökologische Bilanzierung.*
- (2) Statistisches Bundesamt.
- (3) BMFT (1990): *Nachwachsende Rohstoffe.*
- (4) Ch. Roesch (1997): *Monitoring "nachwachsende Rohstoffe", Pflanzliche Öle und andere Kraftstoffe aus Pflanzen, Dritter Sachstandsbericht. TAB Arbeitsbericht Nr. 53.*
- (5) European Parliament: *Briefing Note N° 07/2001, Bio-ethanol added to fuel.*
- (6) Berg, C. (2001): *World Ethanol Production 2001.*
- (7) [http://europa.eu.int/comm/energy\\_transport/atlas/htmlu/lbpot1.html](http://europa.eu.int/comm/energy_transport/atlas/htmlu/lbpot1.html).
- (8) M. Bekers, U. Viesturs (1998): *Integrated bio-system for biofuel production from agricultural raw materials in Latvia,*  
[www.ias.unu.edu/proceedings/icibs/bekers/paper.htm](http://www.ias.unu.edu/proceedings/icibs/bekers/paper.htm).
- (9) IEA.



Module	F2	Ethanol from maize
<b>General description of the process, regional aspects, outlook</b>		

The production of ethanol from biomass results from micro-biological conversion, i.e. fermentation of a sugary solvent by yeast (*Saccharomyces cerevisiae*) or via bacteria (*Zymomonas mobilis*).

The production of bio-ethanol from maize is realised only in selected locations (e.g. USA). The manufacturing of bio-ethanol from starchy raw materials is more expensive than the fermentation of sugary plant content substances but technically feasible (see module F1).

The starch is hydrolysed by enzymatic or thermal swelling during pre-treatment. In the saccharification process afterwards, the accrued oligosaccharides have to be cracked via enzymes or acids in monosaccharides which may be utilised for fermentation later.

The incurred distillation residues (mashes) are by-products. They are partly rehashed within the plant. Mashes can be used humid or dried as forage or fertiliser. The feeding of fresh mashes is directly tied to the production because of its slight durability. The dehumidification of mashes is technically no problem. Nonetheless, it changes the energy balance of bio-ethanol production.

Corn gluten feed arises as a by-product and is marketable. Corn gluten has little raw-fibre-content and high protein- and colorimeter-content.

The cracked sugar is converted by yeast in a subsequent process (metabolism) to ethanol and CO<sub>2</sub>:

1 kg glucose (C<sub>6</sub>H<sub>12</sub>O<sub>6</sub>) → 0.51 kg bio-ethanol (C<sub>2</sub>H<sub>5</sub>OH<sub>10</sub>) + 0.49 kg carbon dioxide (CO<sub>2</sub>)

The resulted liquidity or mash contains on average 5-12 % bio-ethanol. The growth of the biological yeast population decelerates by a higher concentration of alcohol in the mixture and would stop as a consequence of it. The fermentation process is closed after 35-50 hours.

The conversion to bio-ethanol in a process using bacteria is more continuous and faster (it is finished after 20 hours). However, the use of bacteria requires a totally sterile mode of operation.

The separated share of the bio-ethanol is concentrated up to 96 % (vol.) by distillation. The required purification of 99.8 % (vol.) is achievable with the help of the molecular-screen-distillation or by the use of Cyclohexan as an entrainer.

Pure ethanol freezes at -114 °C, boils at 78 °C and has a density of 0.79 kg dm<sup>-3</sup> at 20 °C. The energy content is comparable with gasoline. The possible use of ethanol is similar to the use of conventional fuels.

### Regional aspects

Bio-ethanol from maize is produced in the USA (as a form of ETBE) and in China. Actually, bio-ethanol from maize is not produced within the EU countries.

### Outlook

See also module F1: Ethanol form sugar beet.

## Sources

- (1) BMFT (1990): Nachwachsende Rohstoffe.
- (2) Roesch, C. (1997): Monitoring "nachwachsende Rohstoffe", Pflanzliche Öle und andere Kraftstoffe aus Pflanzen, Dritter Sachstandsbericht. TAB Arbeitsbericht Nr. 53.
- (3) Berg, C. (2001): World Ethanol Production 2001.
- (4) European Parliament: Briefing Note N° 07/2001, Bio-ethanol added to fuel.
- (5) Bekers, M., Viesturs, U. (1998): Integrated bio-system for biofuel production from agricultural raw materials in Latvia,  
[www.ias.unu.edu/proceedings/icibs/bekers/paper.htm](http://www.ias.unu.edu/proceedings/icibs/bekers/paper.htm).

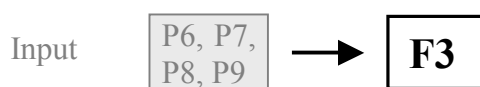

Module	F3	Ethanol from cereals
<b>General description of the process, regional aspects, outlook</b>		

Ethanol is a clear, uncoloured liquid. Ethanol from biomass is referred to as "bio-ethyl-alcohol". In some countries, it is already common as fuel under the name "gasohol". Ethanol can be mixed with gasoline with a share of 10-85 %. Ethanol is produced from vegetable raw materials in a process of fermentation and distillation.

- The **fermentation** describes the process of the transformation of the glucose, which is contained in the input materials, to ethanol and carbon dioxide via yeast enzyme.
- Afterwards, the solvent is **distilled** and with it the ethanol concentrated. 96 % ethanol and 4 % water is the max. achievable concentration. The remaining water can be detracted via chemical substances. A concentration level of 100 % can be accomplished.

A modern mash-procedure with enzymatic saccharification and continuous fermentation is the basis of the production of fuel alcohol from wheat. The mash is separated in a thin and a thick phase. A share of the thin mash is evaporated in the mash procedure. Afterwards, it is dehumidified together with the thick mash. The end product is DDGS (Distiller's Dried Grain & Soluble) a high-quality, transportable and tradable feed stuff with approximately 24-30 % protein and a water content of 10 %. The distillation takes place in the same type of manufacture plant as it is used by the production of ethanol from sugar beets.

The total energy demand of the ethanol production is 156 kWh t<sup>-1</sup> wheat and 0.08 kWh kg<sup>-1</sup> pure alcohol. Thereby, different processing levels are passed through: mashing, fermentation and subsidiary plants as well as distillation and mash evaporation. 293.5 kg respectively 372 litre pure alcohol can be produced from the starch of 1 ton of wheat.

Pure ethanol freezes at -114 °C, boils at 78 °C and has a density of 0.79 kg dm<sup>-3</sup> at 20 °C. The energy content is comparable with gasoline. The possible use of ethanol is similar to the use of conventional fuels.

### Regional aspects

Spain became the largest bio-ethanol producer in the EU by 2004, when the third and largest plant in Salamenca started to produce. The plant has a production capacity of two million hl and uses biomass (cereals, wheat). One bio-ethanol plant exists in Cartagena with a total capacity of one million hl per year from barley. But Germany has increased its production capacity in the last year as well.

### Outlook

In Spain ethanol is transformed into ETBE (185,000 t a<sup>-1</sup>) in existing MTBE installations. See also module F1: Ethanol form sugar beet.

Sources
---------

- (1) Kaltschmitt, M., Reinhardt, G. (2001): *Nachwachsende Energieträger - Grundlagen, Verfahren, ökologische Bilanzierung.*
- (2) Statistisches Bundesamt.
- (3) BMFT (1990): *Nachwachsende Rohstoffe.*

- (4) Roesch, C. (1997): Monitoring "nachwachsende Rohstoffe", Pflanzliche Öle und andere Kraftstoffe aus Pflanzen, Dritter Sachstandsbericht. TAB Arbeitsbericht Nr. 53.
- (5) Berg, C. (2001): World Ethanol Production 2001.
- (6) Scharmer, K.: Alternative Fuels from Renewable Resources, GET - Gesellschaft für Entwicklungstechnologie mbH, Jülich.
- (7) Bekers, M., Viesturs, U. (1998): Integrated bio-system for biofuel production from agricultural raw materials in Latvia,  
[www.ias.unu.edu/proceedings/icibs/bekers/paper.htm](http://www.ias.unu.edu/proceedings/icibs/bekers/paper.htm).



Module	F4	Ethanol from potatoes
<b>General description of the process, regional aspects, outlook</b>		

Ethanol is a clear, uncoloured liquid. Ethanol from biomass is referred to as "bio-ethyl-alcohol". In some countries, it is already common as fuel under the name "gasohol". Ethanol can be mixed with gasoline with a share of 10-85 %. Ethanol is produced of vegetable raw materials in a process of fermentation and distillation.

- The **fermentation** describes the process of the transformation of the glucose, which is contained in the input materials, to ethanol and carbon dioxide via yeast enzyme.
- Afterwards, the solvent is **distilled** and with it the ethanol concentrated. 96 % ethanol and 4 % water is the max. achievable concentration. The remaining water can be detracted via chemical substances. A concentration level of 100 % can be accomplished.

For the production of alcohol from potatoes, it can be assumed that the size of the manufacture plant is comparable to a sugar beet plant. Hence, the same distillation procedure is used. The difference with production of bio-ethanol from sugar beet or wheat is that the mash can be recycled in small amounts (approximately 15 %) because of procedural cause. The mash comprises a high concentration of water. Therefore, an evaporation of the mash is presently not suggestive, because of a high energy input need.

41.2 kWh t<sup>-1</sup> potatoes and 0.2455 kWh kg<sup>-1</sup> pure alcohol are used for the different processing levels (mashing, fermentation, distillation, wash water treatment, mash evaporation). 82.1 kg respectively 104.6 litre pure alcohol can be produced per 1 ton potatoes with a starchy content of 17 %. This is equivalent to a maximum possible crop of ethanol of 85 %. The ratio between mash and pure alcohol is supposed to be 1 litre mash per 1 litre pure alcohol.

Pure ethanol freezes at -114 °C, boils at 78 °C and has a density of 0.79 kg dm<sup>-3</sup> at 20 °C. The energy content is comparable with gasoline. The possible use of ethanol is similar to the use of conventional fuels.

### Regional aspects

The production of bio-ethanol from potatoes in the EU-15 is unknown. Only in Latvia grain, potato and sugar beet are used for bio-ethanol production.

### Outlook

See also module F1: Ethanol from sugar beet

### Sources

- (1) Kaltschmitt, M., Reinhardt, G. (2001): *Nachwachsende Energieträger - Grundlagen, Verfahren, ökologische Bilanzierung.*
- (2) Statistisches Bundesamt.
- (3) BMFT (1990): *Nachwachsende Rohstoffe.*
- (4) Roesch, C. (1997): *Monitoring "nachwachsende Rohstoffe", Pflanzliche Öle und andere Kraftstoffe aus Pflanzen, Dritter Sachstandsbericht. TAB Arbeitsbericht Nr. 53.*

- (5) Bekers, M., Viesturs, U. (1998): Integrated bio-system for biofuel production from agricultural raw materials in Latvia,  
[www.ias.unu.edu/proceedings/icibs/bekers/paper.htm](http://www.ias.unu.edu/proceedings/icibs/bekers/paper.htm).



Module	F5	Ethanol from wood or straw
<b>General description of the process, regional aspects, outlook</b>		

The production of ethanol from biomass results from micro-biological conversion, i.e. fermentation of sugary solvents by yeast (*Saccharomyces cerevisiae*) or via bacteria (*Zymomonas mobilis*).

The production of bio-ethanol from wood and straw are more difficult from the procedural point of view as cellulose and hemicellulose that is synthesised by glucose units have a crystalline structure. These structures complicate the inward flow of enzymes or sour catalysts. Furthermore, these structures are protected by lignin.

At the moment, the conversion of ligno-cellulose is generally possible by two different processes:

**Acid decomposition** was already examined at the beginning of the 20<sup>th</sup> century and was used in times of crises. However, this process has only small chances in the future because of its technical problems, inefficiency and environmental incompatibility.

**Enzymatic hydrolysis decomposition** has already been tested in pilot plants in France, Austria, Japan, Canada and the USA concerning its technical applicability. A large-scale technical experiment, including economical viewpoints, is still missing. Results of the decomposition process are different forms of cracked sugars.

They are converted by yeast in a subsequent process (metabolism) into bio-ethanol and carbon dioxide:

1 kg glucose ( $C_6H_{12}O_6$ ) → 0.51 kg bio-ethanol ( $C_2H_5OH_{10}$ ) + 0.49 kg carbon dioxide ( $CO_2$ )

The resulting liquidity or mash contains on average 5-12 % bio-ethanol. The growth of the biological yeast population decelerates by a higher concentration of alcohol and would stop as a consequence of it. The fermentation process is finished after 35-50 hours.

The conversion to bio-ethanol in a process using bacteria is more continuous and faster (it is finished after 20 hours). However, the use of bacteria requires a totally sterile mode of operation.

The separated share of the bio-ethanol is concentrated to up to 96 % (vol.) by distillation. The required purification of 99.8 % (vol.) is achievable with the help of the molecular-screen-distillation or by the use of Cyclohexan as an entrainer.

Pure ethanol freezes at  $-114\text{ }^{\circ}C$ , boils at  $78\text{ }^{\circ}C$  and has a density of  $0.79\text{ kg dm}^{-3}$  at  $20\text{ }^{\circ}C$ . The energy content is comparable with gasoline. The possible use of ethanol is similar to the use of conventional fuels.

### Regional aspects

The Nordic countries (Norway, Sweden and Finland) have vast wood resources from forests that can form the basis for the production of ethanol. Such production is taking place today as a by-product of wood-processing. In all three countries several studies have shown that available wood resources are large enough to produce 100 % motor-alcohol for the whole transport sector without limiting other users of wood resources or weakening environmental limits. Sweden is most active in the development of ethanol production from woody biomass.



## Outlook

In Sweden, the largest barrier to the spreading of bio-ethanol blends of fuels is the above mentioned Directive. The Directive has been interpreted in Swedish environmental law such that gasoline mixed with 5-30 % ethanol cannot be sold as normal gasoline. Sweden, alone in Europe, has persuaded national car producers to guarantee that their cars can adapt to 10-20 % blends of ethanol. These blends are of course higher than those permitted by the Swedish law and can therefore not be used.

<b>Sources</b>
----------------

- (1) BMFT (1990): Nachwachsende Rohstoffe.
- (2) Roesch, C. (1997): Monitoring "nachwachsende Rohstoffe", Pflanzliche Öle und andere Kraftstoffe aus Pflanzen, Dritter Sachstandsbericht. TAB Arbeitsbericht Nr. 53.
- (3) Jonk, G. (2002): European Environmental Bureau (EEB) background paper 18-03-2002, On the use of biofuels for transport.
- (4) European Parliament, Briefing Note N° 07/2001, Bio-ethanol added to fuel.



Module	F6	Biogas from animal excr. or non-woody plants
<b>General description of the process, regional aspects, outlook</b>		

Digestion plants were first built for waste water treatment. Towards the end of the second world war, when fuel was limited, anaerobic digestion became popular. Half of the gas was utilised to run vehicles. The major design criteria for agricultural biogas plants depend on the mode of feeding and the substrate characteristics (dry matter or suspend solids etc.). To digest substrates with more than 15 % of solid concentration a discontinuous batch-system is used. Here the plant is fed once and after three or four weeks it is emptied. The predominant waste material in agricultural digestion is animal waste (manure and/or slurry with total solid concentrations between 6-12 %). It is co-digested with energy crops and harvest remains, for instance. The most common digester system is the continuous-flow tank reactor. The raw material is pumped regularly into a digester, displacing an equal volume of digested material. An agricultural biogas plant is usually built up of the following elements. First there is a pre-treatment tank for buffering, size reduction and premixing the manure and the other agricultural feedstock. Nearby there is the digester which is fed from the pre-treatment tank semi-continuously (from once or twice a day to intervals less than one hour) by screws or pumps. The digester itself is a gas-tight tank which is mostly made out of concrete or steel. It is insulated because there must be a fixed optimal temperature inside. The predominant types of digestion are the so-called mesophilic digestion (with about 35 °C) and the thermophilic digestion (with about 55 °C). Inside the digester there is a stirrer. This stirrer is responsible for complete mixing of the digesters contents. The major reasons for mixing are: distribution of heat to achieve an even temperature throughout the digester and avoiding or disruption of swimming layers and/or sedimentation. The average hydraulic retention time (HRT) is (depending on substrates) between 20-40 days. The anaerobic degradation occurs in three basic steps as a result of the activity of a variety (at least four different groups) of microorganisms.

The first step is the hydrolysis. The animal or plant matter is decomposed by exo-enzymes to soluble and usual-sized molecules (such as sugar) which are taken up by the bacteria. In the second step (fermentation) the products of the hydrolysis are converted by fermentative bacteria into acids. In the third step (methane formation) the acids are converted to methane gas. Further methane is also formed from hydrogen and CO<sub>2</sub> by methanogenic bacteria. The major components of the resulting biogas are: methane (CH<sub>4</sub> from 50-70 %), carbon dioxide (CO<sub>2</sub> from 25-40 %) and 0-5 % of various other gases such as sulphuric acid (H<sub>2</sub>S).

After drying and cleaning the gas it is stored in a gas holder. The gas holder makes a continuous supply of a gas or diesel gas engine possible. Here heat and electricity are produced. The second output of the process is the digested substrate. It is stored in a normal manure storage tank (uncovered/covered) before being used as a fertiliser.

### Regional aspects

Most countries are interested in using biogas for combined heat and power (CHP) production to increase the supply with green electricity. In Sweden, there is a strong interest in using biogas as a vehicle fuel, due the relative low prices of electricity and heat. In countries such as Germany, Denmark and Austria, the investors in anaerobic technology receive investment subsidies, a higher sale price for electricity and reduced interest of bank loans. In Italy, the

Netherlands and the UK there are also federal and regional programmes to develop and support renewable energies including biogas. In Belgium, Greece, Ireland and Portugal there are no special rules regarding legislation, guidelines, standard policies and fiscal actions.

Another problem in many countries is a lack of appropriate legislation regarding the limit values of heavy metals in digested materials. Therefore, regulations such as waste, nitrate, fertiliser and sewage sludge directives have a potential impact on the use of digestate as organic fertiliser. Furthermore, there are different legislations regarding the nutrient (nitrogen) load on farmland and the storage capacities of digestate. The concern for human and animal welfare has led some countries to legislate on pathogen control.

### Outlook

In a recent survey undertaken by ALTENER Energy from waste Network (EfW), the total amount of agricultural waste in the 15 EU countries was estimated. A result was that even in "developed" countries such as Germany and Austria only a minor part (0.5-3 %) of this huge amount is currently treated in agricultural anaerobic digesters. Probably improved and uniform programmes for investment subsidies and an EU-wide electricity-feed-in-law would lead to a doubling of the share of energy production from biogas plants in the next 15 years.

### Sources

- (1) Nordberg, A. (1999): Legislation in different European countries regarding implementation of anaerobic digestion. AD-Nett, Technical Paper 33 p.
- (2) Steffen, R., Szolar, O., Braun, R. (1999): Feedstocks for anaerobic digestion. AD Nett Technical Paper 21.
- (3) Wellinger, A. (1999): Process design of agricultural digesters.
- (4) Klinger, B. German Biogas Association (1998): Environmental aspects of Biogas technology.
- (5) <http://www.ad-nett.org>.



<b>Module</b>	<b>E1</b>	<b>Wood combustion for electricity/heat generation</b>
<b>General description of the process, regional aspects, outlook</b>		

Wood is transported from collection points to power-plants. A pre-treatment is necessary to generate small wood chips. The wood is burned in the power-plant, where water is evaporated. The produced steam generates electricity in a turbine.

Burning wood for producing electricity is the most common method of using wood as an energy source.

Economic and ecological frame conditions are fixed in dependence on national laws and regulations (such as for German conditions BiomasseV and EEG; according to German law demands maximum size of new biomass-power-plants is 20 MW<sub>e1</sub>).

### Regional aspects

The technology has no relevant regional specifications.

### Outlook

For this well approved technology, no significant technological changes are assumed. A slight increase in efficiency is possible.

### Sources

- (1) [www.biomasse-info.net](http://www.biomasse-info.net).
- (2) [www.fnr.de](http://www.fnr.de).
- (3) [www.bioenergie.de](http://www.bioenergie.de).
- (4) [www.carmen-ev.de](http://www.carmen-ev.de).
- (5) <http://bine.fiz-karlsruhe.de/>.
- (6) [www.verbraeucherministerium.de](http://www.verbraeucherministerium.de).
- (7) [www.bmu.de](http://www.bmu.de).
- (8) [www.iwr.de](http://www.iwr.de).



<b>Module</b>	<b>E2</b>	<b>Straw combustion for electricity/heat generation</b>
<b>General description of the process, regional aspects, outlook</b>		

Straw is transported from the farms to power-plants.  
 The straw is burned in the power-plant, where water is evaporated.  
 The produced steam generates electricity in a turbine.

Economic and ecological frame conditions are fixed in dependence on national laws and regulations (such as for German conditions BiomasseV and EEG; according to German law demands maximum size of new biomass-power-plants is 20 MW<sub>el</sub>).

### Regional aspects

Today, commercial straw-based power plants exist only in Denmark.

### Outlook

Other countries in the EU, like Germany, are building straw-based power plants. The technology will undergo further distribution within the EU.

<b>Sources</b>
----------------

- (1) [www.biomasse-info.net](http://www.biomasse-info.net).
- (2) [www.fnr.de](http://www.fnr.de).
- (3) [www.bioenergie.de](http://www.bioenergie.de).
- (4) [www.carmen-ev.de](http://www.carmen-ev.de).



<b>Module</b>	<b>E3</b>	<b>Biogas combustion for electricity/heat generation</b>
<b>General description of the process, regional aspects, outlook</b>		

Combined heat and power plants (CHP) represent an approved and field-tested technology. For producing electricity and heat in a CHP biogas can be used like natural gas, diesel fuel etc. A CHP is an installation where a simultaneous generation of usable heat and power (usually electricity) is feasible in a single process. The basic elements of a CHP plant comprise one or more prime movers (motor) usually driving electrical generators. The heat generated in the process is utilised via suitable heat recovery equipment for a variety of purposes including: industrial processes, community heating and space heating. CHP can provide a secure and highly efficient method of generating electricity and heat at the point of use. Due to the utilisation of heat from electricity generation and the avoidance of transmission losses (because electricity is generated on-site) CHP typically achieves a 35 % reduction in primary energy usage compared to the separate production of heat and power.

### Regional aspects

The technology has no relevant regional specifications.

### Outlook

CHP is considered as a tool for the EU in order to achieve its energy policy objective of improving energy efficiency and its environmental objective of reducing greenhouse gas emissions. The European Commission estimates that doubling the amount of CHP electricity in the EU will result in CO<sub>2</sub> reductions corresponding to half those to which the EU has committed itself.

In 1994, the electricity generation by CHP plants was about 204 TWh (or 9 % of the total electricity generation). According to analysis, a doubling of the share of CHP from 9-18 % of the total gross electricity generation of the Community produced by CHP by the year 2010 is realistically achievable. The environmental benefits of this would be significant. A rough estimate indicates that, if a doubling of CHP share was achieved, it could reduce CO<sub>2</sub> emissions by 150 megaton per year or approx. 4 % of the total EU CO<sub>2</sub> emissions in 2010. In 1998 22 million people in the EU, or 6 % of its population were supplied with district heating.

### Sources

- (1) Blockheizkraftwerke '99. Technik und Entwicklung, Wirtschaftlichkeit, Betriebserfahrung: (1999), VDI-Gesellschaft Energietechnik.
- (2) Praxis Kraft-Wärme-Kopplung: Wolfgang Suttor, Verlag C.F. Müller, Karlsruhe.
- (3) BHKW Kenndaten 2001, Module- Anbieter- Kosten: (2001), ASUE e.V. Kaiserslautern.
- (4) Nordberg, A. (1999): Legislation in different European countries regarding implementation of anaerobic digestion. AD-Nett.
- (5) <http://www.folkecenter.dk>.
- (6) <http://www.chp-info.org/techniques>.



Module	H1	Hydrogen from electrolysis
<b>General description of the process, regional aspects, outlook</b>		

Hydrogen (H<sub>2</sub>) is a reactive, colourless, odourless and unflavoured gas. It can be produced by numerous different processes. The production of hydrogen is possible from fossil fuels like natural gas or coal. Equally, hydrogen production is possible from biological sources like biomass or by water via electrical current (electrolysis).

Hydrogen can be produced from water by electrolysis and the use of electrical energy. The handling of hydrogen is difficult because of several reasons. An economy of scale is not possible before all technical barriers are solved.

Today and in the near future electrolysis is used for the production of hydrogen from water. The conventional form of water electrolysis is alkaline electrolysis which has been commercially utilised at ambient pressure, for more than 80 years.

By the end of the 1980s, an estimated share of only 0.5-1 billion Nm<sup>3</sup> a<sup>-1</sup> hydrogen (only approx. 0.1-0.2 % of the world production) was directly produced by electrolysis, mostly in connection with water power as a primary energy source. However, these slight amounts decrease presently, since electrolytic hydrogen production for fertiliser production is no better than fertiliser production from natural gas.

Electric current is necessary for the electrolytic production of hydrogen. Hence, a possible location can only be economical where the electric current is extremely cheap.

In future, also local solutions are imaginable (hydrogen as storage for the supply of isle-grid-systems, e.g. wind-hydrogen) in an energy supply system that is based on renewable energy sources.

#### **Principal procedure:**

The fragmentation of water by electrolysis consists of 2 part-reactions on both electrodes. These electrodes are separated by an ionic-conductive electrolyte. Hydrogen originates on the negative electrode (cathode) and oxygen on the positive electrode (anode). Thus, water is fragmented in H<sub>2</sub> and ½ O<sub>2</sub> by the input of electric work and heat.

The necessary charging compensation occurs by ionic-conduction. To make sure that a division of the production gases takes place, the two reaction rooms must be separated by an ionic-permeable diaphragm.

#### **Regional aspects**

The technology has no relevant regional specifications.

#### **Outlook**

For this well approved technology, no significant technological changes are assumed.

<b>Sources</b>
----------------

- |  |
|--|
| <ol style="list-style-type: none"> <li>(1) Auf dem Wege zu neuen Energiesystemen, Bundesministerium für Forschung und Technologie, 1975.</li> <li>(2) www.hydrogen.org.</li> </ol> |
|--|



Module	H2	Hydrogen from biomass by thermochem. conv.
<b>General description of the process, regional aspects, outlook</b>		

Gasification is the thermal-chemical conversion to a fuel gas by partial oxidation. This happens by the under-stoichiometric addition of free or bounded oxygen.

**General gasification procedure:** heating up - drying - pyrolysis - oxidation - reduction

At first, the biofuel-particle is heated up. Thereby, the contained water (respectively the additionally inserted water in the reactor) evaporates at a temperature level of approx. 200 °C. Biomass consists of macromolecules. A thermal induced fragmentation of these macromolecules takes place at temperatures between 150-500 °C after the heating up and the drying procedure of the particles. Thereby, gaseous carbon hybrid connections, pyrolysis-oil and pyrolysis-coke emerge.

By the oxidation, the developed gaseous, liquid and solid products react with oxygen under the impact of heat. This affects a temperature increase of over 500 °C.

The main part of the combustible substances of the produced gas is produced by the reduction afterwards. Thereby, the emerged combustion products of the oxidation CO<sub>2</sub> and H<sub>2</sub>O are reduced to CO and H<sub>2</sub>.

The free product gas composition depends on many factors, e.g.:

- physical and chemical properties of the fuel
- kind and quantity of the gasification medium
- reactor times
- reactor type (fixed bed, fluidised bed (bubbling or circulating))
- gasification temperature
- pressure
- catalysts etc.

The major problem concerning the application of the produced gasification gas - both by the use in the gas engine / turbine and by the planned use in the H<sub>2</sub> production - are the high dust and tar contents in spite of an expensive gas clean-up.

A conversion is required by the transformation of the produced synthesis gas from the biomass gasification. A similar procedure is necessary for reforming natural gas. Thereby, flush-gases (H<sub>2</sub>, CO, CO<sub>2</sub>, CH<sub>4</sub>) result during the fine-purification of hydrogen in the pressure-change-adsorption-plant. Then, the flush-gas can be used in a gas turbine or combustion engine.

### Regional aspects

The technology has no relevant regional specifications.

### Outlook

The availability of this procedure is expected in the next 2-3 years.



<b>Sources</b>
----------------

- (1) [www.hydrogen.org](http://www.hydrogen.org).
- (2) Tetzlaff: Synergie von Wasserstoff und Biomasse nutzen. Deutscher Wasserstoffverband.
- (3) The use of Producer Gas from Biomass Gasification for Electricity Production in a Gas Engine, Norwegian university of science and technology, March 2001.
- (4) Graf von Stillfried, N. (1996): Wasserstofftechnologie aus der Sicht des Bayrischen Wirtschaftsministeriums. Vortrag anlässlich der "World Hydrogen Energy Conference" WHEC 11 in Stuttgart, 1996.
- (5) Kaltschmitt, M., Hartmann, H.: Energie aus Biomasse.



Module	H3	Hydrogen from natural gas
<b>General description of the process, regional aspects, outlook</b>		

Steam reforming is defined as the endothermic catalytic transformation of light carbon hybrids (from methane to naphtha) with water steam. These processes are run in the industrial production at temperatures of 800-900 °C and pressures of about 2.5 MPa normally. Afterwards, the exothermic catalytic transformation (shift-reaction) of the formed carbon monoxides with water vapour takes place:

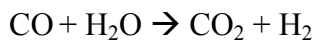

The energy released by this reaction can not directly be used for the reforming process because of its high temperature level (200-500 °C). The carbon dioxides are removed from the gas mixture by adsorption or membrane separation. In addition, it must be cleaned of further undesirable substances. The remaining gas has 60 % of combustible substances (H<sub>2</sub>, CH<sub>4</sub>, CO) and is used together with a part of the insert-gas for the heating of the reformer. Large steam-reforming-plants have a production capacity of up to 100,000 Nm<sup>3</sup> H<sub>2</sub> hour<sup>-1</sup> per unit. Also smaller plants are available on the market for the local hydrogen production (e.g. in the semiconductor industry). The procedure is well-engineered. Thus, a H<sub>2</sub>-purification of 99.9 % is attained.

### Regional aspects

The technology has no relevant regional specifications.

### Outlook

For this well approved technology, no significant technological changes are assumed.

Sources
---------

- (1) [www.hydrogen.org](http://www.hydrogen.org).



Module	S1	Esterification of vegetable oils
General description of the process, regional aspects, outlook		

Vegetable oil can be produced from oil seeds like the rape plant. It can indirectly be used in conventional diesel engines after a process of refinement - the transesterification.

Rape seed oil consists of 95-98 % of tri-glycerine. Oleic acid is its most important fatty acid with 54-64 %, followed by linoleic acid (16-22 %) and linolenic acid (8-10 %). The high content of macromolecular tri-glycerine is responsible for the higher viscosity of rape-seed oil in comparison to diesel fuel. In the case of transesterification, the trivalent glycerol-alcohol contained in the tri-glycerine is replaced by an univalent alcohol (methanol or ethanol) by the catalytic conversion process (see Figure 4). The resulting rape-oil-fatty-acid-methyl-ester (RME = biodiesel) is characterised by: a lower viscosity, a lower tendency to carbonisation, a better frost resistance and a higher cetane number than rape seed oil. On the basis of RME's similarity with petroleum diesel, it can be mixed together without noteworthy problems of stability. RME can be used as a substitute for diesel fuel nearly without any special modification of existing engines

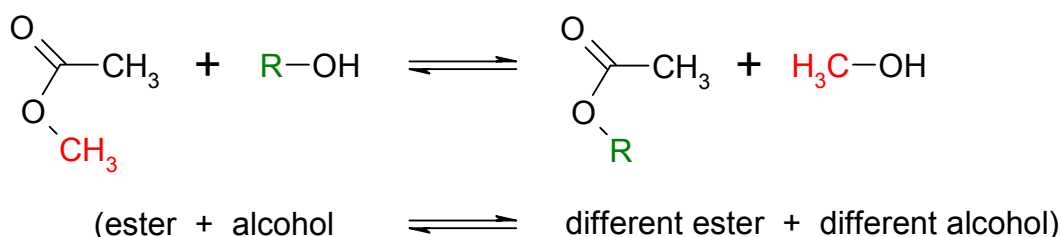

**Figure 4:** Reaction scheme of the esterification process

The transesterification of vegetable oil to biodiesel is accomplished in **processors** that are a combination of reaction and still vessels. Batch processing is convenient for small productions (no more than 10,000 t year<sup>-1</sup>). In industrial continuous machines, the reaction and distillation of alcohol is in batches and the decantation is continuous.

**Industrial processors.** In the static mixer, the base, the methanol and vegetable oil are mixed. In the reactor, esterification of free fatty acids occurs. In the second static mixer a catalyst is added to the methanol-oil mix for the transesterification. In the third mixer, the product of the reaction (biodiesel, glycerol and methanol solvent) are neutralised by introducing a mineral acid. In the flash vaporiser (distillation unit), the alcohol is separated. The vapours of methanol are condensed and sent to the reception unit to be introduced again in the cycle. The remaining products in the flash vaporiser (biodiesel, glycerol, salts and water) are sent to the continuous decanter, to separate biodiesel from the rest of the by-products. The light phase of the solution in the decanter is sent to the storage tank and the heavy phase (impure glycerol and salts) is sent to another storage tank for later purification. It contains 90 % pure glycerol, water and salts.

Typical values of raw materials and consumables to produce 1 t of biodiesel and glycerol (85 % min.) are: 1,010 to 1,040 kg rape oil, 6-7 kg catalyst (mostly NaOH), 102-109 kg methanol and depending on the procedure 1-6 kg acids. 93-112 kg raw glycerol emerges as a co-product of the esterification. For this procedure, about 52 kWh (188 MJ) of electricity,

1,674 MJ of process heat, 20 m<sup>3</sup> of cooling water and 3.2 m<sup>3</sup> of nitrogen per ton of RME output are needed.

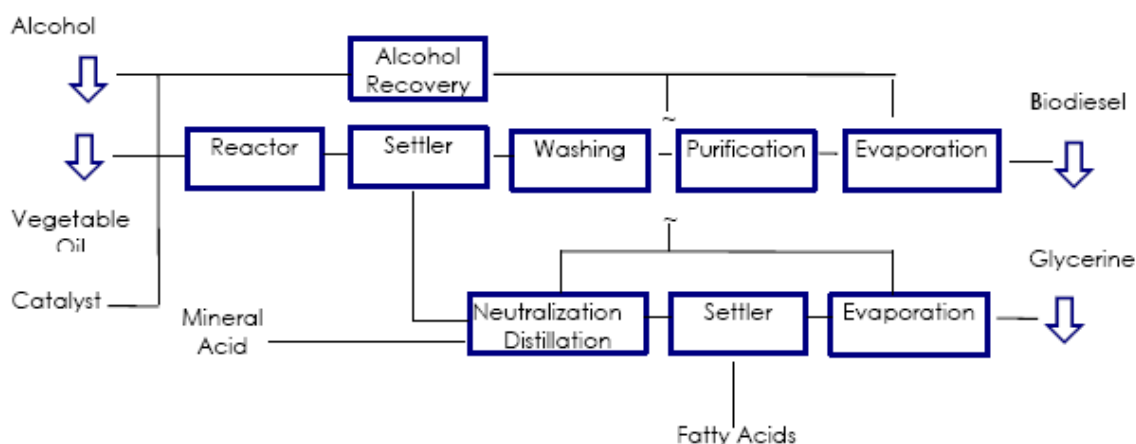

**Figure 5:** General process scheme

### Regional aspects

The provision of vegetable-oil-methyl-ester (VME) is state of the art. RME, as the major VME produced in Europe, can be purchased at many filling stations. The greatest amount of RME produced and used in Europe is in Germany followed by France and Italy. Many vehicle manufacturers have allowed RME to be used with their products.

### Outlook

For this well approved technology, no significant technological changes are assumed.

### Sources

- (1) <http://bioenergy.ornl.gov/doeofd/index.html>.
- (2) <http://pubs.acs.org/journals/esthag-a/links/energy.html#biofuels>.
- (3) <http://www.eurec.be/htm/expertise/biomass.htm>.
- (4) <http://www.afdc.nrel.gov/altfuel/biodiesel.html>.
- (5) <http://www.dlr.de/TT/system/publications/epolitik>.
- (6) <http://www.ufop.de/home.html>.
- (7) <http://www.umweltbundesamt.de/uba-info-presse-e/presse-informationen-e/p0100e.htm>.



<b>Module</b>	<b>S2</b>	<b>Methyl ester from used vegetable oils</b>
<b>General description of the process, regional aspects, outlook</b>		

The esterification process corresponds to the esterification of unused vegetable oils (see module S1). The difference is the need for cleaning of the used oil in the first place. It can contain several other substances.

### Regional aspects

The first experiences with esterification of used vegetable oil have been in Great Britain. There is no information about the application of this technology in other European countries.

### Outlook

Important technical developments are not expected because the potential of raw material for this technology is very limited.

<b>Sources</b>
----------------

- (1) <http://www.afdc.nrel.gov/altfuel/biodiesel.html>.
- (2) <http://www.dlr.de/TT/system/publications/epolitik>.
- (3) <http://www.ufop.de/home.html>.



Module	S3	Biogas upgrading
<b>General description of the process, regional aspects, outlook</b>		

Raw biogas, produced in a digester, is normally treated in order to remove water, H<sub>2</sub>S, dust and/or CO<sub>2</sub>. The choice of the cleaning method and the compounds to be removed depends on the type of end use of the gas.

Removal of water and foam is always needed for the prevention of corrosion in the biogas line. The condensation method (demisters, cyclone separators, moisture traps) and the drying method (adsorption of the gas to silica, glycol drying unit) are the basic methods for removing water. Water removal is normally accomplished with the removal of foam and dust.

A number of techniques have been developed over the years for the removal of H<sub>2</sub>S from biogas. Very low investment and exploitation costs and very easy to realise is the air or oxygen dosing to the biogas system. The technique is based on the biological aerobic oxidation of H<sub>2</sub>S to elemental sulphur ( $2 \text{H}_2\text{S} + \text{O}_2 \rightarrow 2\text{S} + 2 \text{H}_2\text{O}$ ). The results obtained with this method are very promising. Further techniques are: addition of iron chloride to the digester as well as adsorption using iron oxide pellets.

Upgrading of biogas to substitute natural gas (SNG) involves a number of steps. At first, water (vapour) and H<sub>2</sub>S have to be removed. Subsequently, CH<sub>4</sub>/CO<sub>2</sub> separation must be carried out, using one of the following techniques for the removal of CO<sub>2</sub>: pressure swing adsorption, membrane separation and physical or chemical CO<sub>2</sub>-absorption.

If the gas is meant for input in natural gas piping system, the gas has to be cooled and has to be compressed. Dust and (halogenated) hydrocarbons have to be removed, and the gas needs to be odorised for safety reasons.

For utilisation of biogas as vehicle fuels the same upgrade technique is used as for natural gas. In practice, the upgrading of biogas up to vehicle fuel quality involves removal of CO<sub>2</sub>, H<sub>2</sub>S, NH<sub>3</sub>, particles and water. The methane contents should be at least 95 %. Once cleaned and upgraded, biogas is conveyed by pipeline at a pressure of 4 bar (for instance) to a filling station. It is then compressed up to 200 bars.

### Regional aspects

In the EU the requirements for biogas to be injected in natural gas pipelines are different. At the moment no European standard has been defined, but it can be assumed that differences in European countries will be small. Quality requirements of biogas for vehicle fuel are also different across the EU.

### Outlook

The next step to an improved stage of development and better economics in using biogas is providing urban vehicles like buses (public transport) and garbage trucks. More filling stations could be built if the demand for biogas fuel increases (amongst taxis, company and delivery vehicles and private cars). In combination with increasing prices for fossil fuels there could be a fast spreading of gas filling stations especially along important traffic routes outside urban areas. More experiences and a better efficiency of the removal/upgrading techniques will cause lower costs of investment, operation and maintenance.

## Sources

- (1) Evaluation of landfill gas upgrading project Carbiogas B.V: (1992) at Nuenen; Novem / Gastec, The Netherlands.
- (2) Guidebook on landfill gas extraction and utilisation: (1997); Novem / Thermie, The Netherlands .
- (3) Technical summary on gas treatment: (2000); AD Nett; Project Fair CT96-2083 (DG12-SSM).
- (4) <http://www.biogas.ch>.
- (5) <http://www.ad-nett.org>.



<b>Module</b>	<b>S4</b>	<b>Liquefaction of hydrogen</b>
<b>General description of the process, regional aspects, outlook</b>		

Liquefaction of hydrogen is a multi-stage process using several refrigerants and compression / expansion loops to produce extreme cold. As part of the process, the hydrogen passes through "ortho / para" conversion catalyst beds that convert most of the "ortho" hydrogen to the "para" form. The two types of hydrogen are the same, except that in the "para" form the protons in the centre of the two hydrogen atoms making up the hydrogen molecule have the same spin value while in "ortho" molecules they have different spins. "Ortho" hydrogen is less stable than "para" at liquid hydrogen temperatures. It spontaneously changes to the "para" form, releasing energy which vaporises a portion of the liquid. By using a catalyst such as hydrous ferric oxide to convert most of the hydrogen to the more stable form during the liquefaction process, the resultant liquid hydrogen can be stored without excessive ventilation loss.

For transportation and storage, a transformation of hydrogen to its liquid phase is very useful. In this phase the hydrogen can be made useful for fuel cells.

In general, hydrogen can be delivered in gaseous as well as liquid phase. For supply in gas bottles seven times more space is necessary in comparison to supply via liquid hydrogen. However, the liquid condition of hydrogen is interesting in respect to the transportation volume, but the energy input for liquefaction is quite high.

Liquid hydrogen can be stored at temperatures of 20 K at a pressure of 1 bar (0.1 MPa) as well as at 32 K at a pressure of 11 bar (1.1 MPa).

### Regional aspects

The technology has no relevant regional specifications.

### Outlook

	technical data						costs	
	nominal power	hydrogen production	electricity demand	annual capacity in hours	cumulated energy-demand	emissions of CO <sub>2</sub>	investments	specific costs
units	MW	kg h <sup>-1</sup>	kWh kg <sup>-1</sup>	h a <sup>-1</sup>	kWh KWh <sup>-1</sup> (H <sub>2</sub> )	g kWh <sup>-1</sup> (H <sub>2</sub> )	€ kW <sup>-1</sup> (H <sub>2</sub> )	Cent € kWh <sup>-1</sup> (H <sub>2</sub> )
state of the art	21.8	1083	10.5	700	0.01	3	1350	2.3
szenario 2025	107.4	14600	7.4	7500	0.01	3	1100	2.0

### Sources

- (1) [www.hydrogen.org](http://www.hydrogen.org).





<b>Module</b>	<b>S5</b>	<b>Compression of hydrogen</b>
<b>General description of the process, regional aspects, outlook</b>		

When hydrogen is produced through one of the different procedures described above (electrolysis, from biomass or from natural gas), it needs to be compressed before it can be transported in vehicles (transportation to the filling station - if the production site is not integrated within the filling station - and transportation on board vehicles).

For the on-board-transportation in vehicles, a pressure of 70 MPa (at low temperature) or 88 MPa (at room temperature) a booster system (compression system) is needed. This system needs about 0.065 MJ of electrical energy for the compression of 1 MJ of hydrogen.

Compression is achieved with an air and water-cooled trunk piston 3, 4 or 5 stage compressors using the same crankcase. Trunk-piston compressors can be built in oil-lubricated and oil-free executions.

### Regional aspects

The technology has no relevant regional specifications.

### Outlook

For this well approved technology, no significant technological changes are assumed.

<b>Sources</b>
----------------

- (1) [www.hydrogen.org](http://www.hydrogen.org)
- (2) Schindler, J., Weindorf, W. (LBST): "Kraftstoffe aus Erneuerbaren Energien im Vergleich", transparencies from the world forum for renewable energies, Berlin, 2002, and personal information of W. Weindorf, LBST, Ottobrunn.



<b>Module</b>	<b>S6</b>	<b>ETBE from ethanol</b>
<b>General description of the process, regional aspects, outlook</b>		

Ethyl tertiary butyl ether (ETBE) is produced by mixing ethanol and isobutyene (iC4) and reacting them with heat over a catalyst. 0.45 t of ethanol and 0.55 t of iC4 are used for producing 1 t of ETBE.

The butadien-free C4-fraction and ethanol in a mole-ratio 1 : 1 are heated to 60-90 °C before entering the reactor. The chemical reaction takes place at the liquid phase under a pressure of 1-2 MPa over an acid ion-change-catalyst.

ETBE offers equal or greater air quality benefits as ethanol, while being technically and logistically less challenging than ethanol.

### Regional aspects

Fuel-ethers were invented 25 years ago in the EU and Europe is still leading the way with ETBE with relevant experience that has been accumulated in manufacturing, blending and usage of the bio-ethanol-derived products for any "Otto"-cycle engines.

Europe has 7 ETBE plants (France, Spain, Poland) and 6 more being developed, prefers ETBE over ethanol.

Bio-ethanol in form of ETBE is practised in the USA (production from maize) and in Brasilia (production from sugar cane). But, there are tax incentives for the use of bio-ethanol in these countries as well as in France.

### Outlook

For this well approved technology, no significant technological changes are assumed.

ETBE capacity is today around 600,000 t y<sup>-1</sup> in Europe with new capacity planned for another 500,000 t y<sup>-1</sup>. Furthermore, the entire existing MTBE capacity of 3.5 Million tons per year could be converted to ETBE.

ACEA (European Car Manufacturers Association) favours the use of ETBE up to 15 % rather than the direct use of bio-ethanol. In fact, due to its nature, ETBE is fully compatible with the hydrocarbon basic gasoline. It does not create any problem in terms of fuel quality (volatility, material compatibility), neither with respect to the distribution system. Large experience exists on the use of ethers (especially MTBE) blended in gasoline. By employing fuel-ethers such as ETBE the quantity of ethanol that can be used in modern fuels can be maximised without the need to modify existing gasoline regulation. The ether allows 26 % more alcohol in the blend.

### Sources

- (1) EFOA input - EUC RFCBT.doc (Mirabella).
- (2) ETBE - A RFS Solution for the Future - Sept 2002 - Piel - TEIR Associates.ppt.
- (3) W-Mirabella on ETBE – Excerpt from Presentation 2002.ppt.
- (4) [www.itv.tu-clausthal.de/ICVT/forschung/etbe.html](http://www.itv.tu-clausthal.de/ICVT/forschung/etbe.html).
- (5) TU Bergakademie Freiberg, Institut für Energieverfahrenstechnik und Chemieingenieurwesen.

- (6) Biofuels data EU.ppt (some slides as personal communication from EFOA - European Fuel Oxygenates Association, 2003).